



ETB26RT

This telescopic platform is equipped with a fast charging lithium battery pack. This emissions free, energy-saving solution makes the unit suited for working in enclosed spaces. The platform is equipped with 4 steering drive wheels for improved stability on any surface. The boom folds for transport so that the vehicle can be shipped in a container.

TRANSPORT MODE

STANDARD EQUIPMENT

- Proportional controls
- Thumb rocker steering
- Flashing light
- Horn
- Hour counter
- Harsh Environment Kits
- 12V DC Auxiliary Power

PERFORMANCE

- Front oscillating axles to match the terrain irregularities granting optimal adherence to the ground
- 4 Wheels Steering
- Four-wheel drive
- Positive traction four wheel drive
- 360° rotation (continuous)
- Integral Integrated Special Drive Axle

BASKET

- Self levelling platform
- Rotating basket +/-90°
- Power to platform

SAFETY

- Drive enable system
- Platform load sense system
- On-board diagnostics system
- Tilt indicator with alarm
- Crushing protection
- Emergency lowering system

BATTERY

- Lithium battery - Maintenance free
- Powersource : 80V/420Ah
- Charger : -
- Monophase and Three-phase 380V and 220V
- Recharge cycle from 0 to 100% (hours)*: 5,5



ZERO EMISSIONS

STANDARD EQUIPMENT



Construction



Large Events



Aircraft maintenance
Ship repair



Plant Service



Oil & gas



Restoration

ETB26RT

Max. working height	26.30 m
Max. basket height	24.30 m
Max. reach	19.40 m
Max. platform load capacity	454 kg
Max. Occupants	3
Max. gradeability (stowed)	30%
Max. working slope	X-5°/Y-5°
Max. wind speed	12.5 m/s
Turning radius (outside)	3.22 m
Turning radius (inside)	1.87 m
Turret rotation (continuous)	360°
Jib type	Regular
Jib length	2.31 m
Jib movement	-
Jib vertical rotation	135°
Basket width	0.91 m
Basket length	2.44 m
Basket rotation	180°
Total weight	16,090 kg
Travel speed (closed config.)	6.0 km/h
Travel speed (working config.)	1.1 km/h
Tyres	385/45-28
Battery Type	Lithium battery - Maintenance free
Powersource	80V/420Ah
Charger	-
Charger type	Monophase and Three-phase 380V and 220V
Recharge cycle from 0 to 100% (hours)*	5,5
Emergency power system	12V
Driving motors	54VAC/18kW
Lifting motors	-
Engine pump	-
Hydraulic tank capacity	165 l
Transmission	Hydrostatic

*Experimental calculation. The count is affected by climate and usage of the machine.

STANDARDS COMPLIANCE: EN 280, ANSI/SAIA A92.20

LOAD CHART

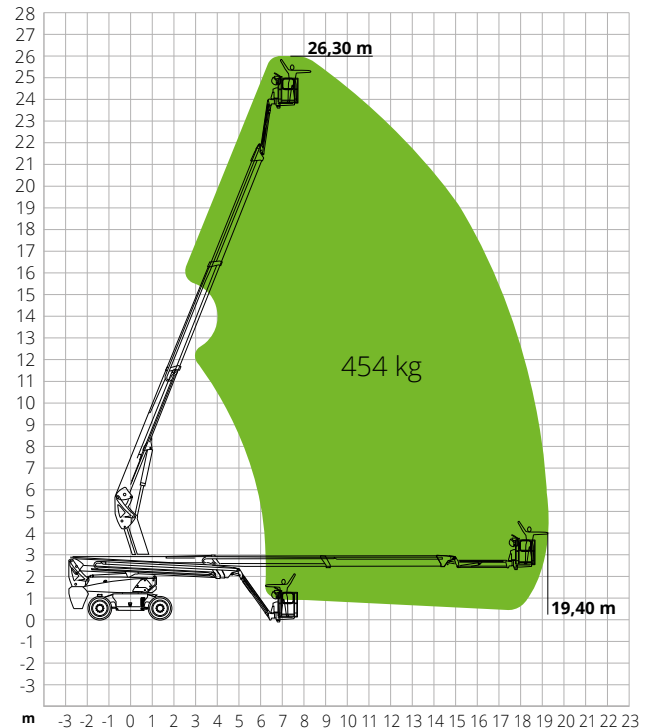

DIMENSIONS

A Platform length	10.80 m
Platform length (transport)	7.95 m
B Platform width	2.50 m
Platform width (transport)	2.50 m
C Platform height	2.87 m
Platform height (transport)	2.89 m
E Wheelbase	2.80 m
Tailswing	1.61 m
D Ground clearance	0.41 m

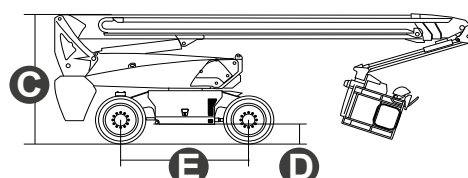
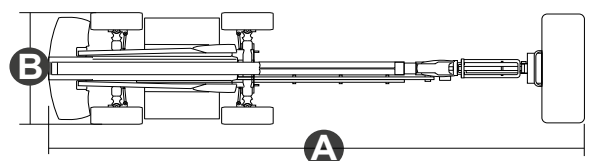

#LIFTDIFFERENT

www.magnith.com



The data in this brochure are provided for the purposes of information and subject to change without notice.