



HTB34RT

This eco-friendly hybrid platform offers excellent efficiency and low running costs. With its Range Extender motor, it can work in electric mode with an extended capacity of up to 30 days. In combination with the IC engine, the Range Extender motor can charge the battery at any time. The platform is equipped with 4 steering drive wheels for improved stability on any surface. The boom folds for transport so that the vehicle can be shipped in a container.



STANDARD EQUIPMENT

- Proportional controls
- Thumb rocker steering
- Flashing light
- Horn
- Hour counter
- Harsh Environment Kits
- 12V DC Auxiliary Power

SAFETY

- Drive enable system
- Platform load sense system
- On-board diagnostics system
- Tilt indicator with alarm
- Crushing protection
- Emergency lowering system

PERFORMANCE

- Front oscillating axles to match the terrain irregularities granting optimal adherence to the ground
- 4 Wheels Steering
- Four-wheel drive
- Positive traction four wheel drive
- 360° rotation (continuous)
- Integral Integrated Special Drive Axle

BATTERY

- Lithium battery - Maintenance free
- Powersource : 80V/420Ah
- Charger : -
- Monophase and Three-phase 380V and 220V
- Recharge cycle from 0 to 100% (hours)*: 5,5
- Engine Range Extender: Kubota Z482/9.8kW

BASKET

- Self levelling platform
- Rotating basket +/-90°
- Power to platform

STANDARD EQUIPMENT



Construction



Large Events



Aircraft maintenance
Ship repair



Plant Service



Oil & gas



Restoration

HTB34RT

Max. working height	34,14 m
Max. basket height	32,14 m
Max. reach	21,60 m
Max. platform load capacity	454 kg
Max. Occupants	3
Max. gradeability (stowed)	X-5°/Y-5°
Max. working slope	30%
Max. wind speed	12,5 m/s
Turning radius (outside)	3,22 m
Turning radius (inside)	1,87 m
Turret rotation (continuous)	360°
Jib type	Regular
Jib length	0,6 m
Jib movement	68°
Jib vertical rotation	135°
Basket width	0,91 m
Basket length	2,44 m
Basket rotation	180°
Total weight	19.290 kg
Travel speed (closed config.)	6 km/h
Travel speed (working config.)	1,1 km/h
Tyres	385/45-28
Battery Type	Lithium battery - Maintenance free
Powersource	80V/420 Ah
Charger	-
Charger type	Monophase and Three-phase 380V and 220V
Recharge cycle from 0 to 100% (hours)*	8
Emergency power system	12V
Driving motors	54V/18kW
Lifting motors	-
Engine pump	-
Engine Range Extender	Kubota Z482/9.8kW
Diesel tank capacity	110 l
Hydraulic tank capacity	165 l
Transmission	Hydrostatic

*Experimental calculation. The count is affected by climate and usage of the machine.

STANDARDS COMPLIANCE: EN 280, ANSI/SAIA A92.20

LOAD CHART

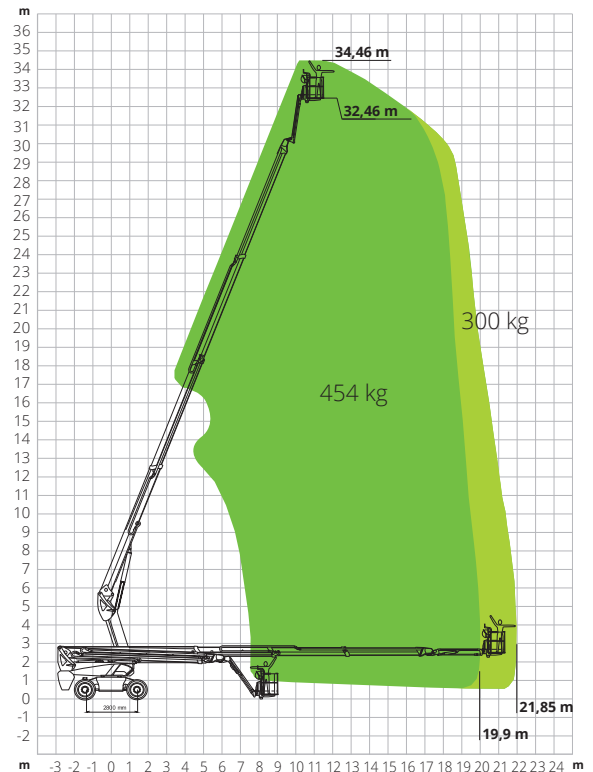

DIMENSIONS

A Platform length	11,63 m
Platform length (transport)	11,79 m
B Platform width	2,28 m
Platform width (transport)	2,50 m
C Platform height	2,86 m
Platform height (transport)	2,58 m
D Wheelbase	2,80 m
Tailswing	1,61 m
Ground clearance	0,41 m

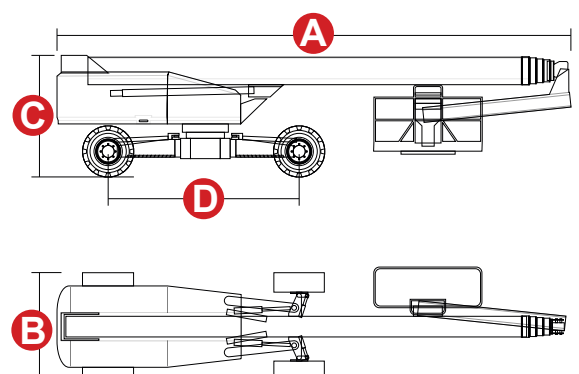

#LIFTDIFFERENT

www.magnith.com



The data in this brochure are provided for the purposes of information and subject to change without notice.