

TH

4,5.19 P



CONSTRUCTION



LOGISTICS



EVENTS AND
FILM



TH
4,5.19 P



CAB

Best-in-class
safety and visibility



PERFORMANCE

Unrivalled lifting
performance



LOAD LIVE DIAGRAM

Two real-time dynamic
load charts

TH 4,5.19 P

DIMENSIONS (ft and in)

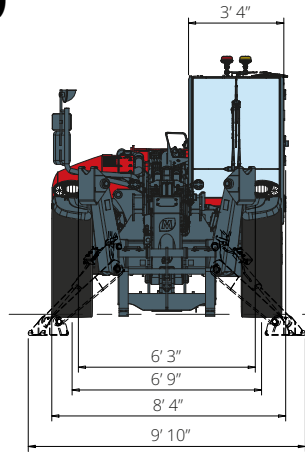

FRONT
view

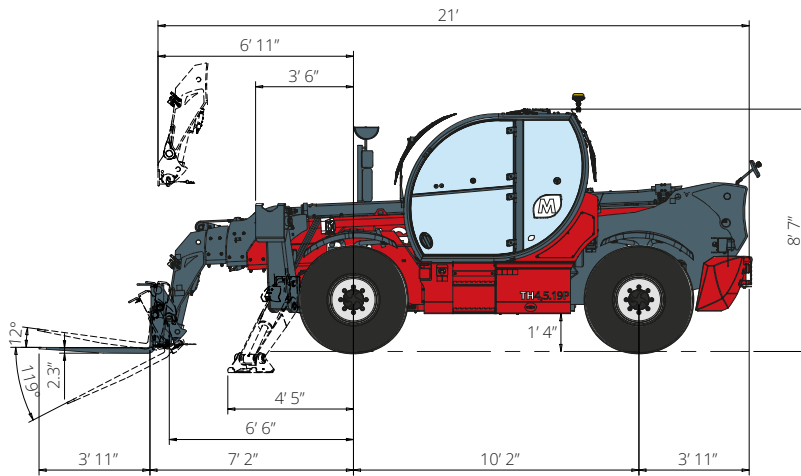

SIDE
view

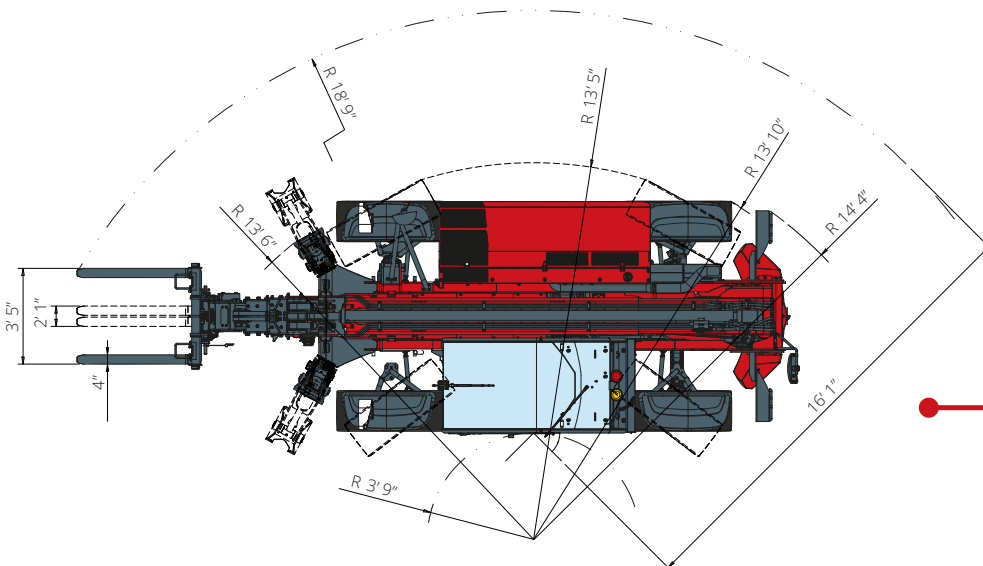

TOP
view

Load chart with
FULLY EXTENDED STABILIZERS

ATT-08-014

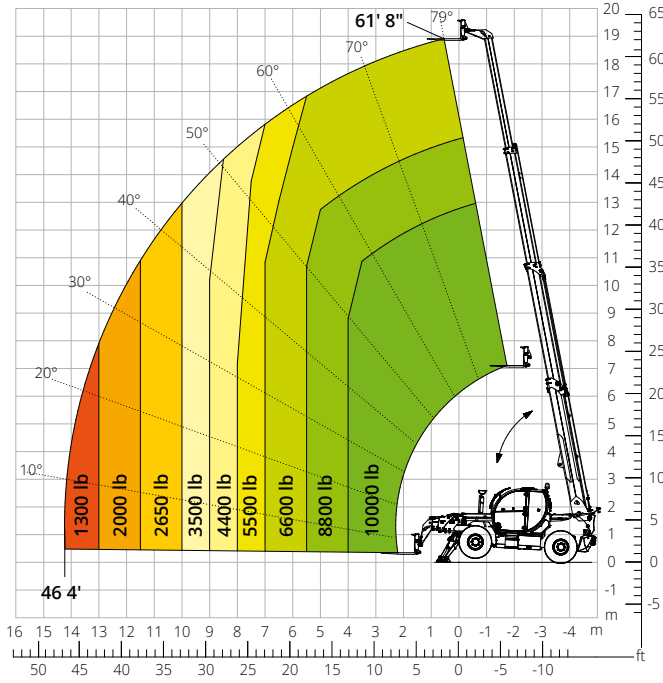

Load chart
FRONT ATTACHMENT ON TIRES

ATT-08-014

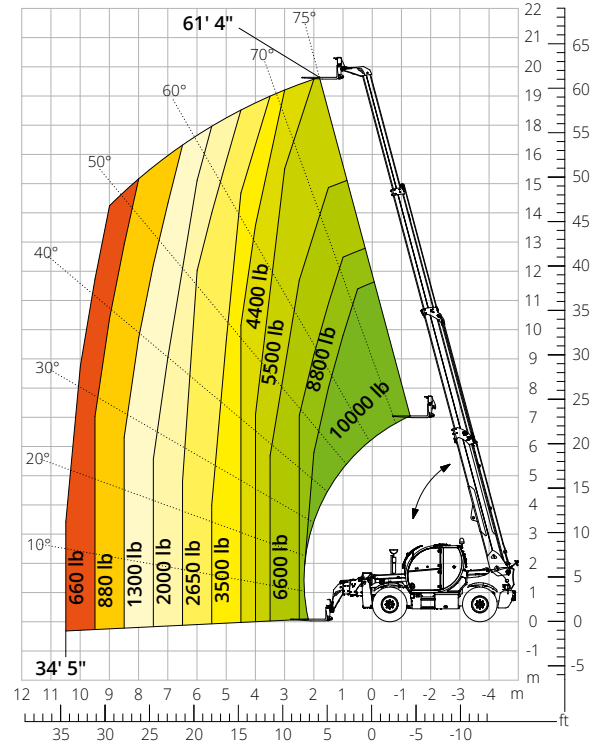

Load chart with
WINCH, 7,700 lb

ATT-02-022

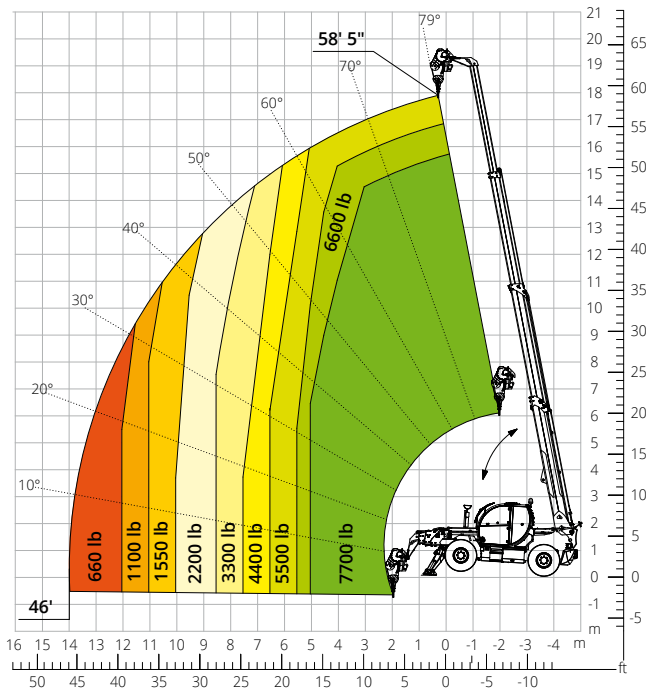

Load chart with
WINCH, 11,000 lb

ATT-02-019

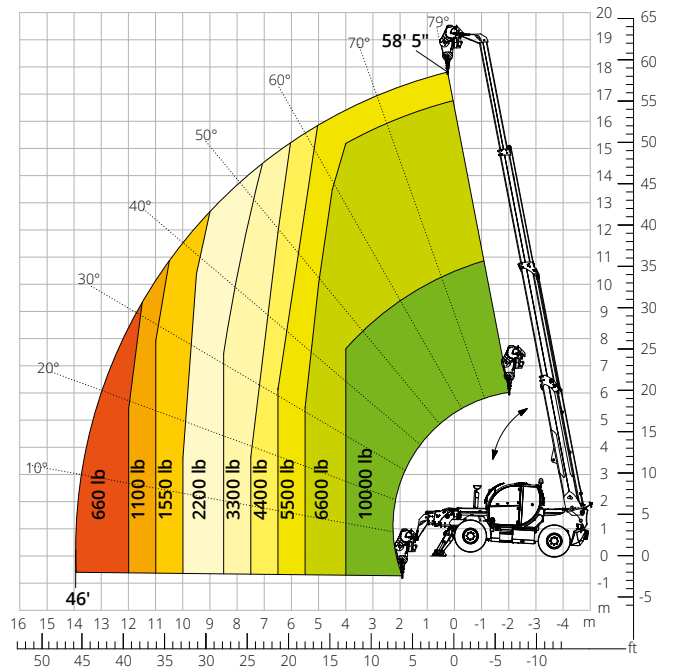

Load chart with
JIB WITH WINCH, 3,300 lb

ATT-04-011

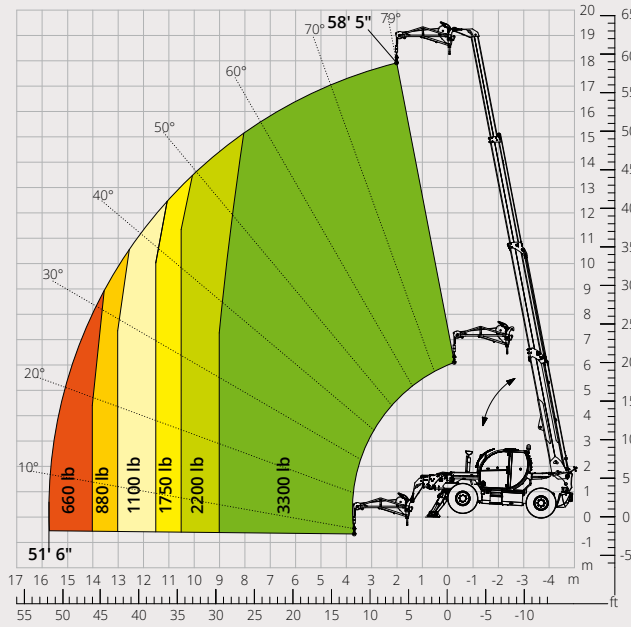

Load chart with
JIB WITH WINCH, 4,400 lb

ATT-04-015

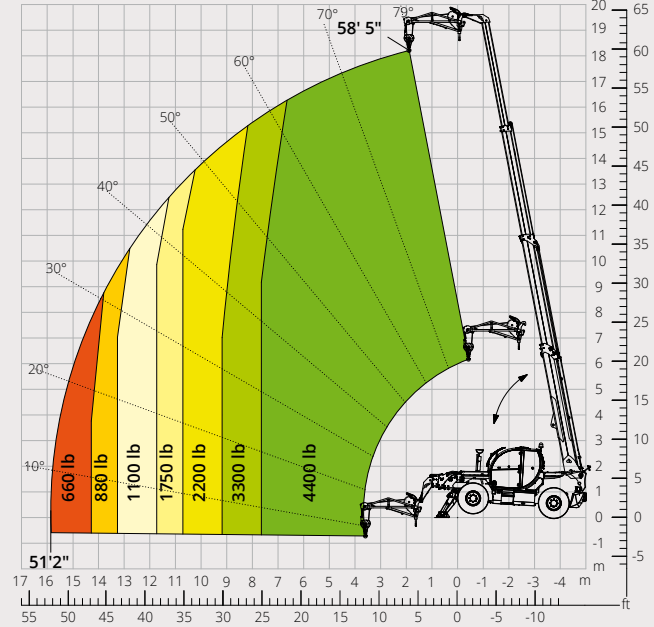

Load chart with
JIB 4,400 lb

ATT-04-013

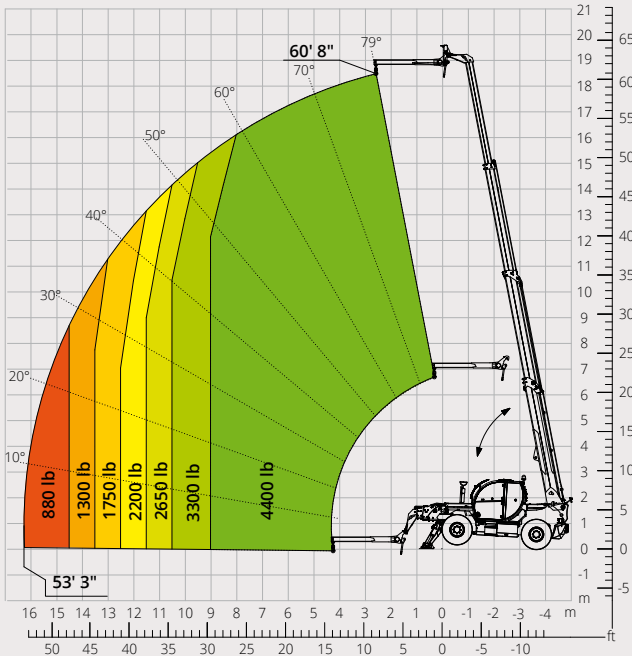

Load chart with
HOOK, 11,000 lb

ATT-05-001

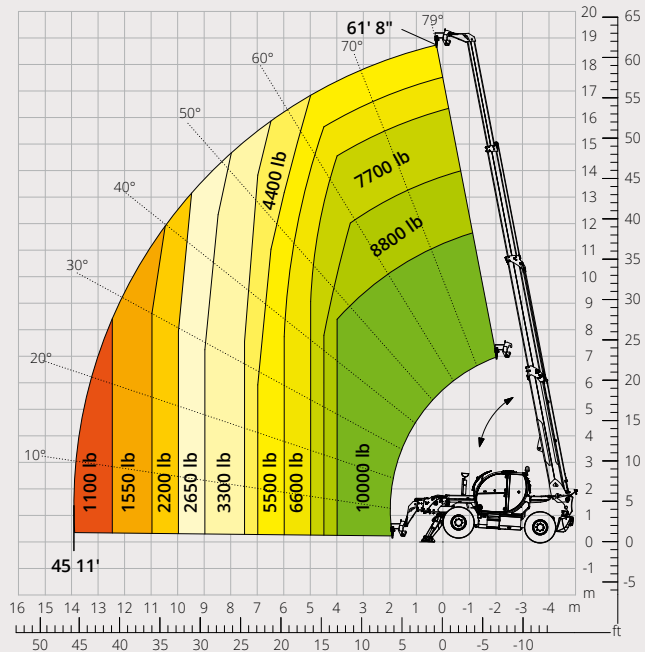

Load chart with
ROTATING EXTENDABLE PLATFORM, 2,200 lb

ATT-01-016

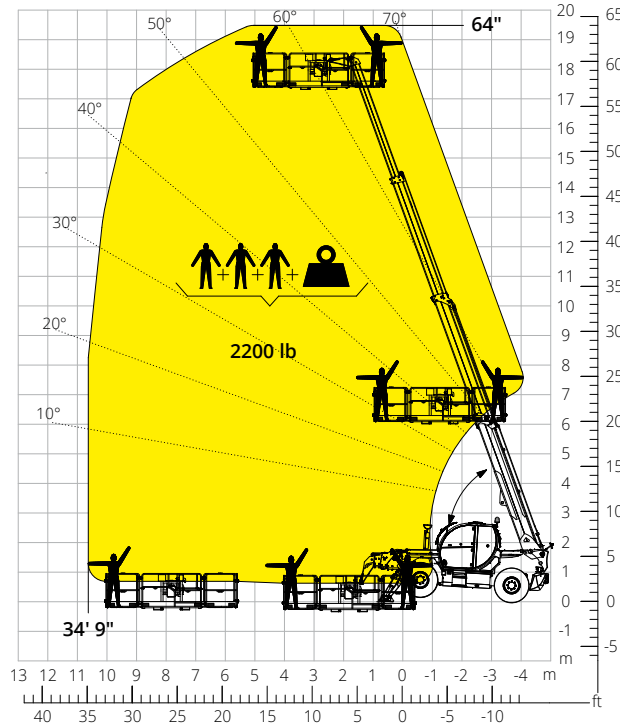

Load chart with
ROTATING NON-EXTENDABLE PLATFORM, 550 lb

ATT-01-003

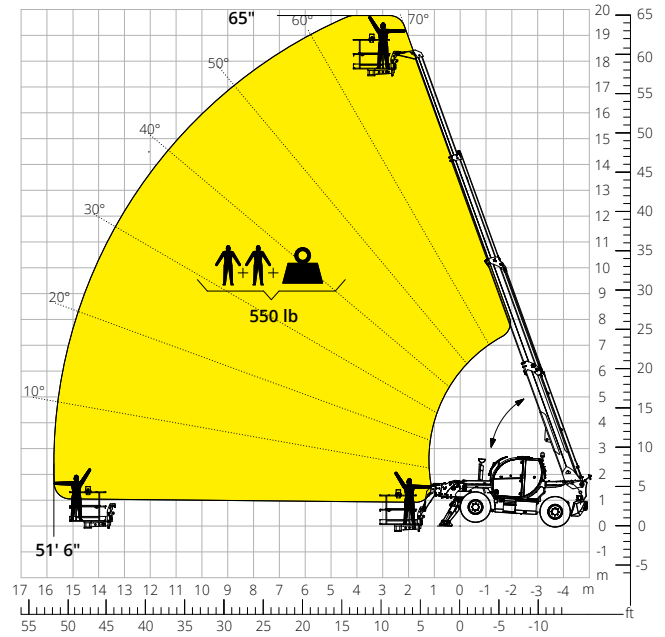

Load chart with
FIXED PLATFORM, 550 lb

AT-01-001

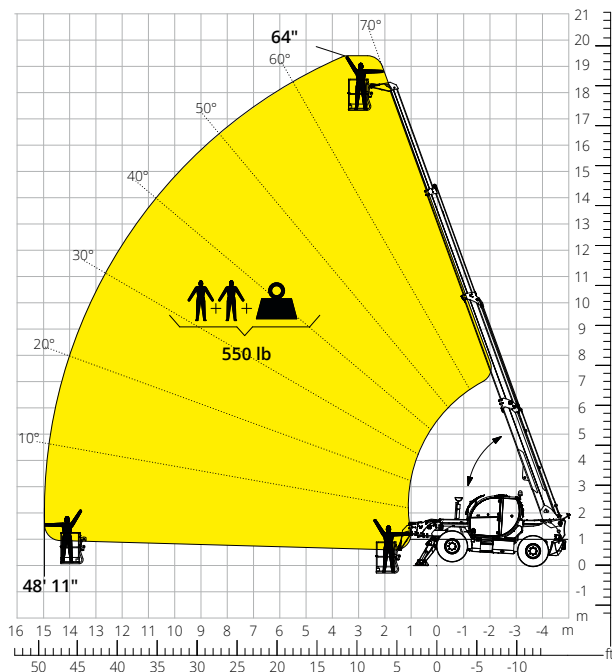

Load chart with
PLATFORM, 1,000 lb, FOR MINES

ATT-01-027

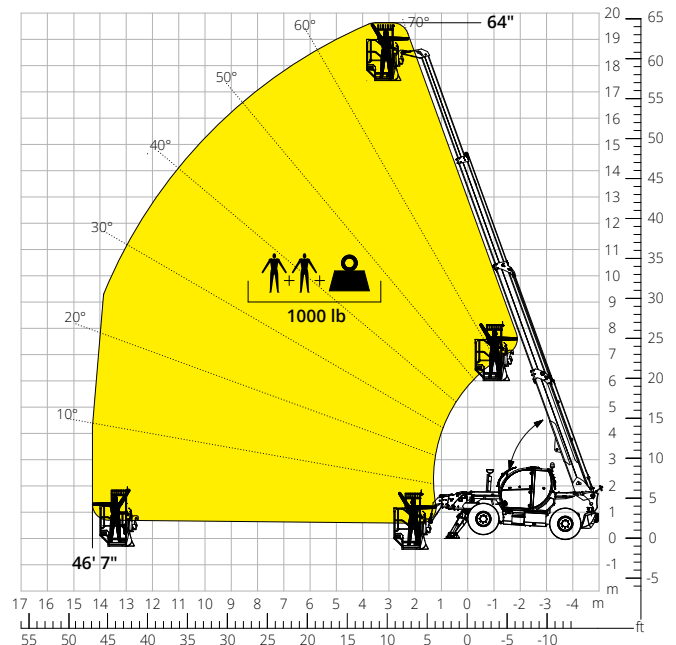

Machine model	Telescopic handler	TH 4,5.19 P	
	Maximum lifting capacity	10,000 lb	
	Maximum lifting height	61' 8"	
	Maximum reach	46' 4"	
Stabilizers	Type	Pivoting	
Engine	Model	Deutz TCD 3,6 L4 EDG - Stage IIIA	Deutz TCD 3,6 L4 Stage V
	Rated power	74.4 kW (101.2 hp) at 2,200 rpm	
	Maximum torque	302 lb/ft at 1,600 rpm	
	Displacement	3.6 l	
	Cylinders	4 in line	
	Engine configuration	Turbocharged direct injection diesel	
	Cooling system	Water – intercooler	
Transmission	Type	Hydrostatic	
	Maximum pressure	530 bar	
	Gear box	Dropbox, 2 speeds forward-reverse	
Axles and brakes	Type	Axles with planetary gearboxes	
	Front axle	Oscillating and steering with levelling, +/-8°	
	Rear axle	Oscillating and steering with hydraulic lock	
	No. of driving/steering wheels	4WD - 4WS	
	Steering mode	Frontal/Concentric/Crab	
	Service brake	Wet multi-disk on front and rear axle	
	Parking brake	Hydraulic with negative action on front axle	
Performance	Tyres dimensions	445/65 R22.5	
	Max. travel speed	21 mph	
	Gradeability (unladen)	58%	
	Turning radius (end of forks)	18'10"	
Weights	Total unladen*	28,000 lb	
	Front axle unladen (boom retracted and lowered)*	12,350 lb	
	Rear axle unladen (boom retracted and lowered)*	15,650 lb	
Tank and system capacities	Fuel tank	52.8 U.S. gal	
	AdBlue	2.64 U.S. gal	
	Hydraulic oil tank	24.6 U.S. gal	
	Engine oil tank	2.4 U.S. gal	
	Cooling liquid	5.3 U.S. gal	
Hydraulic circuit for movements	Circuit type	Load sensing	
	Service pump	Variable displacement	
	Max. hydraulic flow rate	120 l/min	
	Max. boom head flow rate	75 l/min	
	Max. operating system pressure	350 bar	
	Controls for boom movements	SIL 2 electro-proportional valve	
	Movements control	1 joystick with integrated manoeuvre enable	
Standard met	2006/42/EC: EU Machinery Directive		
	2016/1628: EU Regulation on the emissions of stage V engines		
	EN 1459-X: Relating to standards on the safety requirements for variable reach machines		
	EN 280/EN 280-1/EN 280-2: standards relating to mobile elevating work platforms (if available)		
ROPS/level 2 FOPS: relating to the standards for protective structures			

The data given in this brochure are provided for information purposes and are subject to change without prior notice.
All images are purely guideline and might not give an exact representation of the product.

*the stated weight refers to the vehicle unladen with standard equipment and may vary depending on the chosen configuration.

The standard machine configuration includes:

CAB

- Comfort seat with adjustable headrest
- Adjustable steering column
- Analogue joypad
- Adjustable sunblind
- Heating
- Air conditioning
- FM/AM radio with USB and Bluetooth connectivity
- Ambient LED lights
- USB Type-A and Type-C (5 V) inputs

REAL TIME INFORMATION

- Touchscreen, 7"
- MCTS – Magni Combi Touch System on-board software
- Automatic RFID tools recognition system
- LMI – Load Moment Indicator
- LLD – Live Load Diagram
- Onboard and remote integrated diagnostics

TECHNICAL SPECIFICATIONS

- Q-Fit standard
- Provision for platform
- Advanced three-line CAN BUS system
- Automatic levelling system for outriggers
- Automatic front and rear wheel alignment
- Automatic parking brake
- Mechanical battery cut-off in engine compartment
- Electrical system: 24 V – IP67

SERVICE

- Warranty: 24 months/2,000 hours