

RTH

6.31 EC



CONSTRUCTION



LOGISTICS

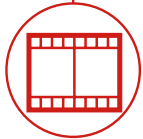

EVENTS AND
FILM



FORESTRY



RTH

6.31 EC



CAB

Best-in-class
safety and visibility



PERFORMANCE

Unrivaled lifting
performance



LOAD LIVE DIAGRAM

Three real-time dynamic
load charts

RTH 6.31 EC

DIMENSIONS (ft and in)

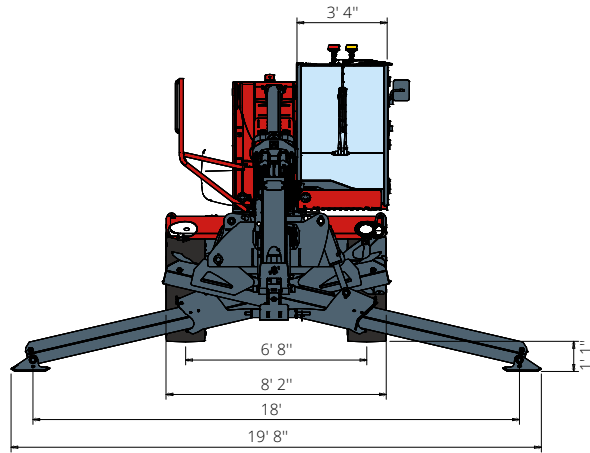

FRONT
view

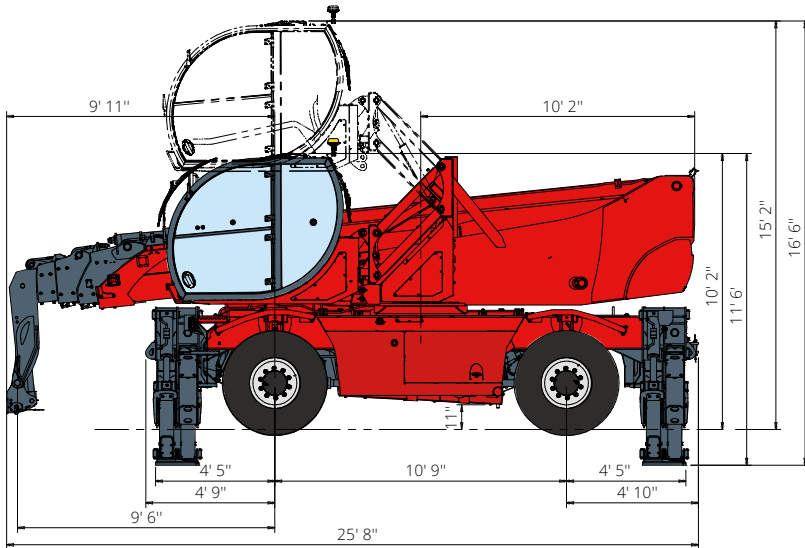

SIDE
view

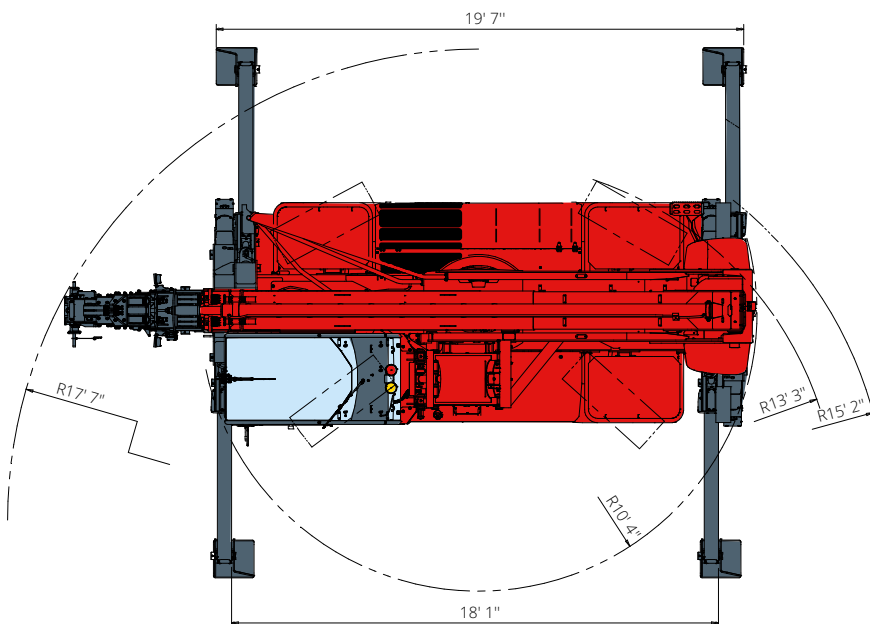

TOP
view

Load chart with
FULLY EXTENDED STABILIZERS (360°)

ATT-03-004

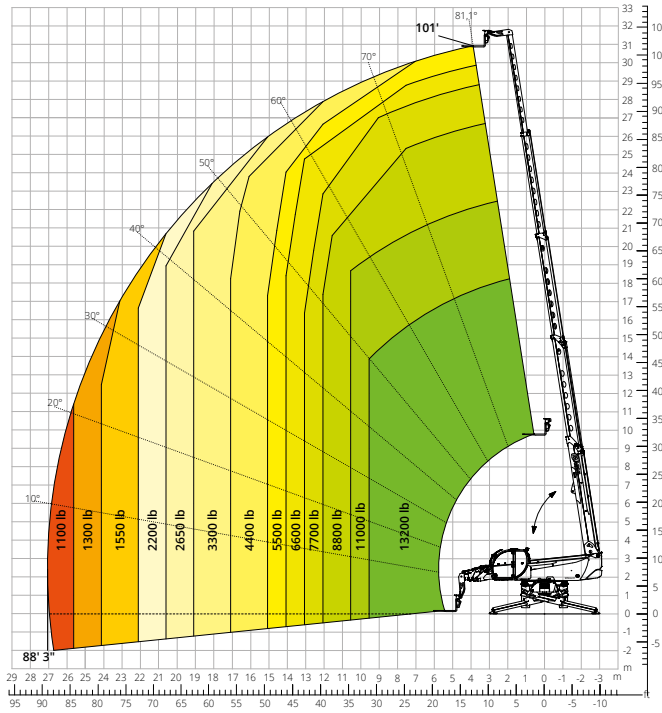

Load chart
FRONT ATTACHMENT ON TIRES

ATT-08-001

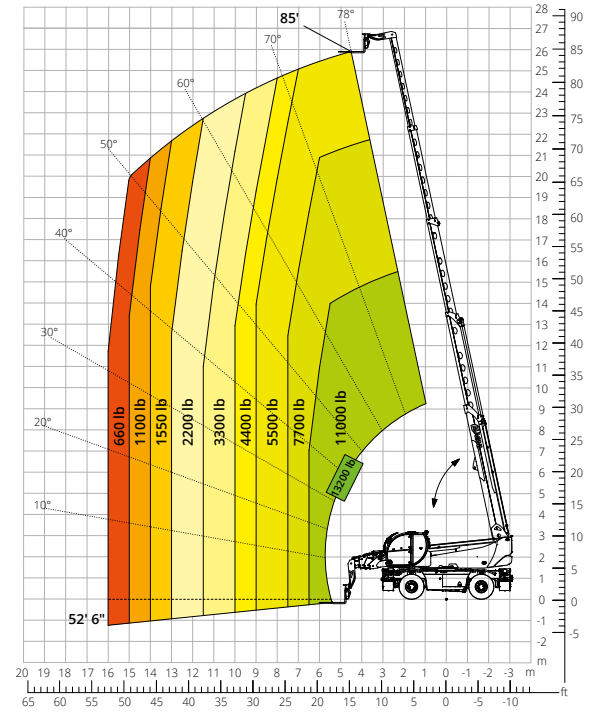

Load chart with
WINCH, 7,700 lb

ATT-02-002

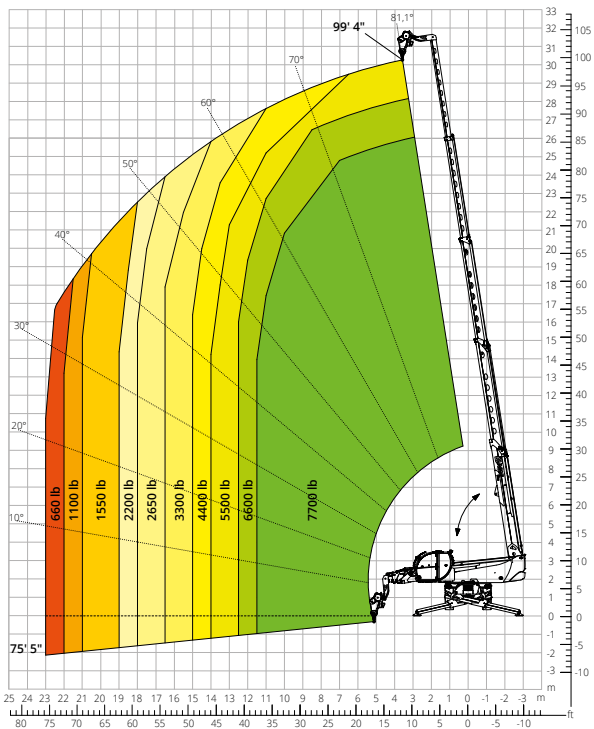

Load chart with
WINCH, 13,200 lb

ATT-02-004

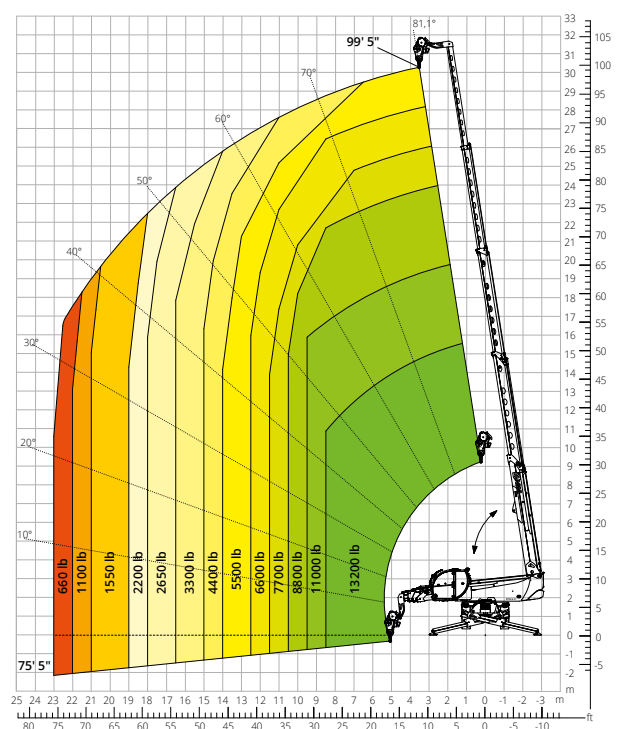

Load chart with
JIB WITH WINCH, 3,300 lb

ATT - 04 - 011



Load chart with
JIB WITH WINCH, 4,400 lb

ATT - 04 - 015

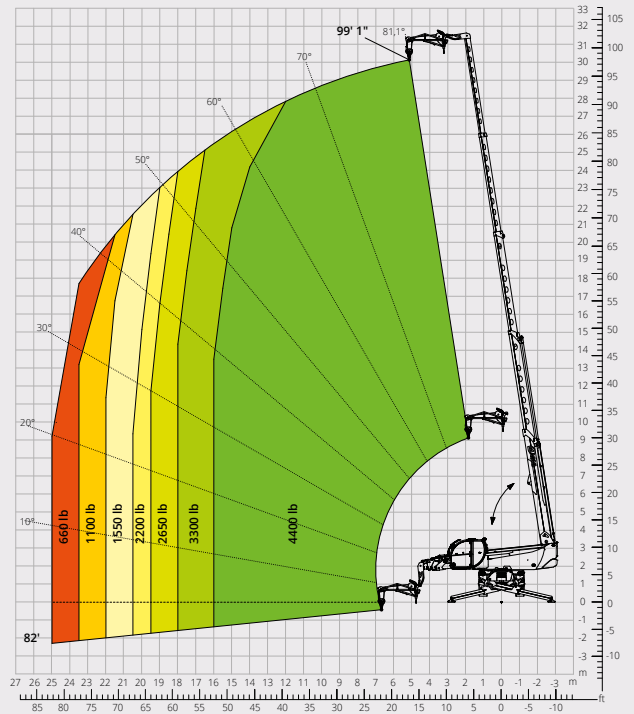

Load chart with
JIB WITH WINCH, 6,600 lb

ATT - 04 - 019

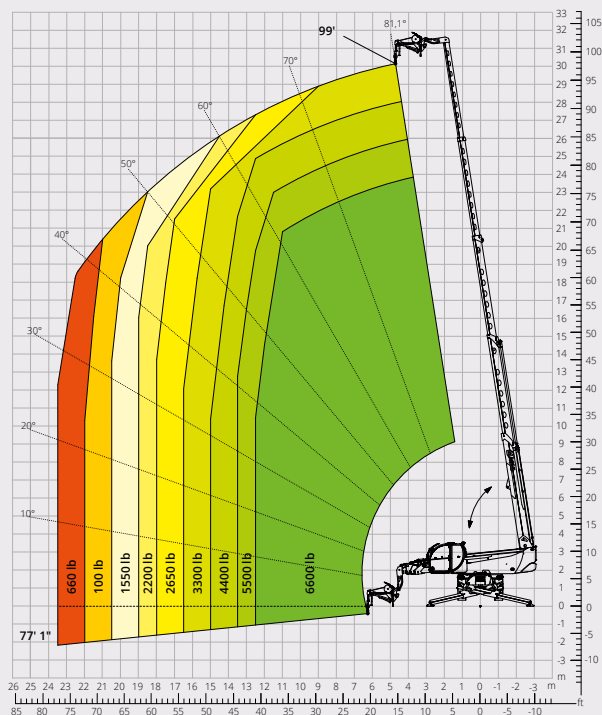

Load chart with
JIB, 4,400 lb

ATT - 04 - 013

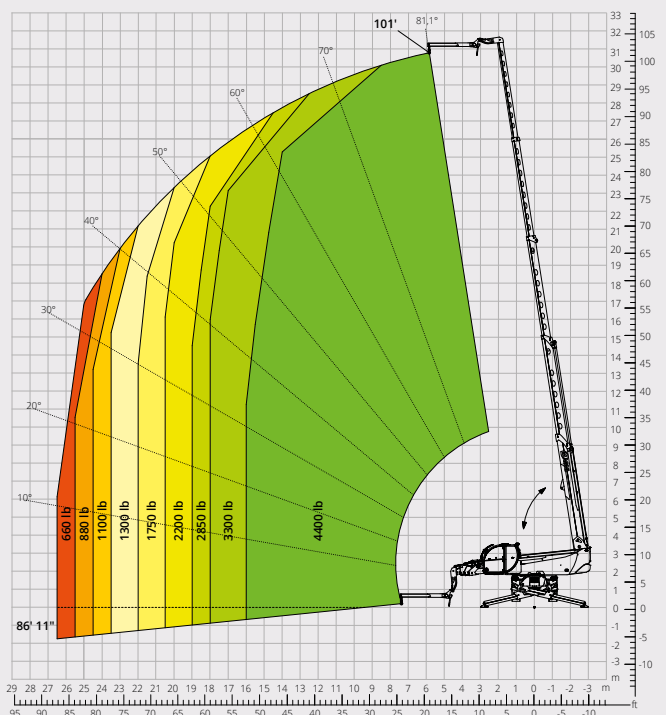

Load chart with
HOOK, 13,200 lb

ATT - 05 - 001

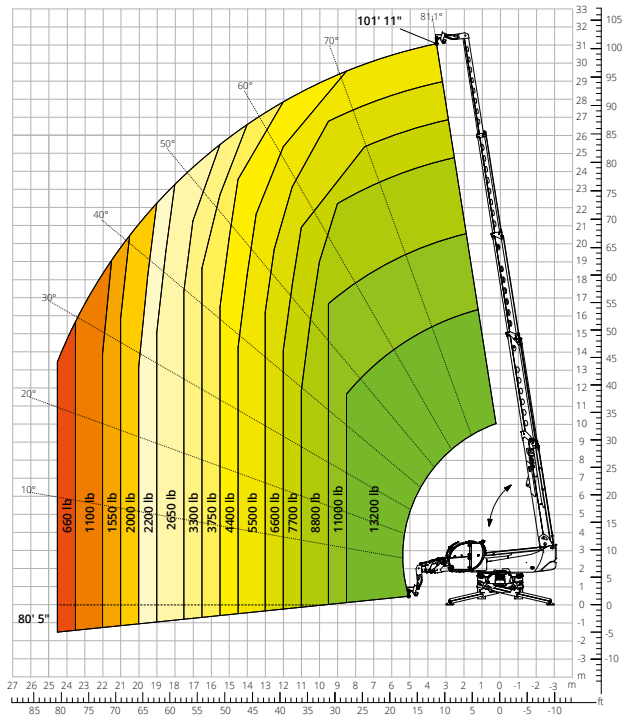

Load chart with
ROTATING EXTENDABLE PLATFORM, 1,100 lb

ATT - 01 - 007

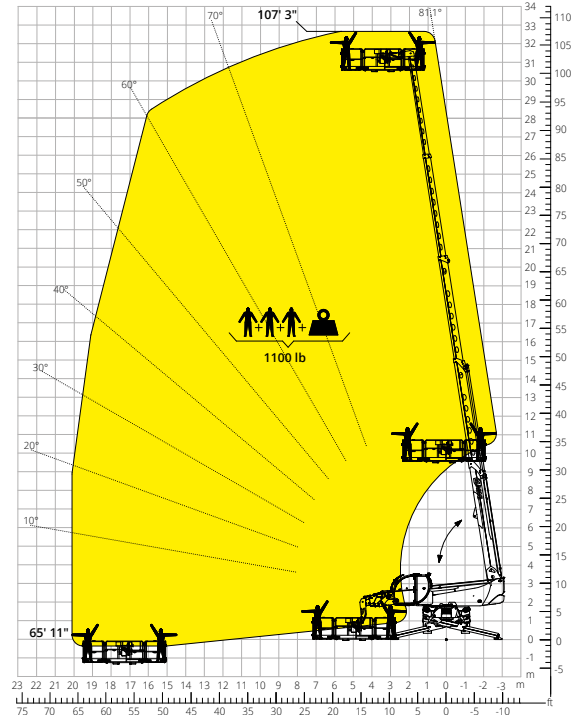

Load chart with
ROTATING EXTENDABLE PLATFORM, 2,200 lb

ATT - 01 - 016

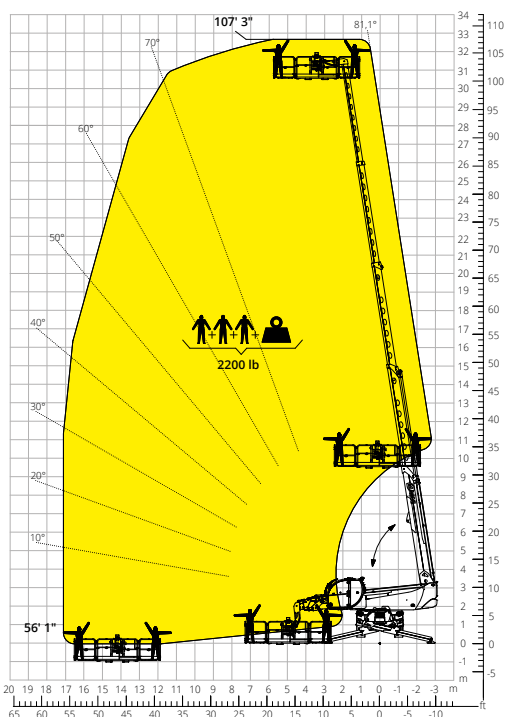

Load chart with
PLATFORM, 1,100 lb, WITH WINCH, 1,300 lb

ATT - 01 - 026

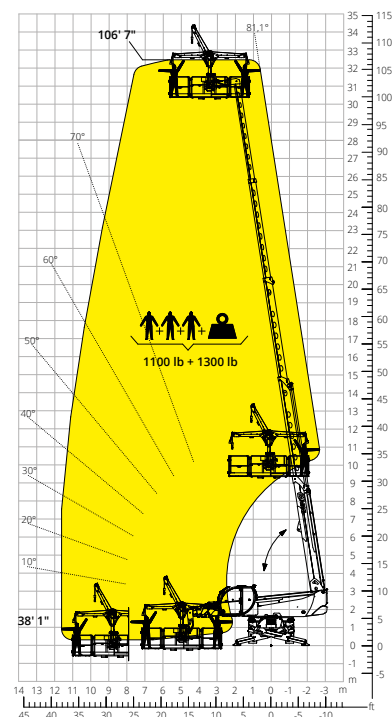

	Rotating telescopic handler	RTH 6.31 EC	
Machine model	Maximum lifting capacity	13,200 lb	
	Maximum lifting height	101'	
	Maximum reach	88' 3"	
	Rotation	360° (continuous)	
Stabilizers	Type	Telescopic scissor	
Engine	Model	Volvo TAD 552 VE Stage IIIA	Volvo TAD 582 VE Stage V
	Rated power	160 kW (218 hp) at 2,200 rpm	160 kW (218 hp) at 2,300 rpm
	Maximum torque	671 lb/ft at 1,450 rpm	682 lb/ft at 1,380 rpm
	Displacement	5.13 l	
	Cylinders	4 in line	
	Engine type	Turbocharged direct injection diesel	
	Cooling system	Water – intercooler	
Transmission	Type	Hydrostatic	
	Maximum pressure	480 bar	
	Gearbox	Dropbox, 2 speeds forward-reverse	
Axles and brakes	Type	Axles with planetary gearboxes	
	Front axle	Oscillating and steering with levelling, +/-8°	
	Rear axle	Oscillating and steering with hydraulic lock	
	No. of steering wheels	4WD - 4WS	
	Steering mode	Frontal/Concentric/Crab	
	Service brake	Wet multi-disk on front and rear axle	
	Parking brake	Hydraulic with negative action on front axle	
	Tyre sizes	445/65 R22.5	
Performance	Max. travel speed**	25 mph	
	Gradeability (unladen)	40%	
	Turning radius (at forks)	22' 1"	
Weights	Total unladen*	50,050 lb	
	Front axle unladen (boom retracted and lowered)*	34,060 lb	
	Rear axle unladen (boom retracted and lowered)*	26,900 lb	
Tank and system capacities	Diesel fuel	71 U.S. gal	71 U.S. gal
	AdBlue	-	10.56 U.S. gal
	Hydraulic fluid	43.3 U.S. gal	43.3 U.S. gal
	Engine oil	4.22 U.S. gal	4.22 U.S. gal
	Coolant	10.56 U.S. gal	10.56 U.S. gal
Hydraulic circuit for movements	Circuit type	Load sensing	
	Service pump	Variable displacement	
	Max. hydraulic flow rate	160 l/min	
	Max. boom head flow rate	75 l/min	
	Max. working pressure	350 bar	
	Distributor for boom and turret movements	SIL 2 electro-proportional valve	
	Movements control	Dual joystick with integrated manoeuvre enable	
Standards met	2006/42/EC: EU Machinery Directive		
	2016/1628: EU Regulation on the emissions of stage V engines		
	EN 1459-X: Relating to standards on the safety requirements for variable reach machines		
	EN 280-1/EN 280-2: standards relating to mobile elevating work platforms (if available)		
	ROPS/level 2 FOPS: relating to the standards for protective structures		

The data given in this brochure are provided for information purposes and are subject to change without prior notice.

All images are purely guideline and might not give an exact representation of the product.

*the stated weight refers to the vehicle unladen with standard equipment and may vary depending on the chosen configuration.

**Max. speed may be limited depending on the country of destination.

The standard machine configuration includes:

CAB

- Elevating and tilting cab +1,5 m / 16° of inclination
- "Easy access" system
- Premium tilting seat with air suspension and headrest
- Adjustable steering column
- Analogue joypad
- Adjustable sunblind
- Heating
- Air conditioning
- FM/AM radio with USB and Bluetooth connectivity
- Ambient LED lights
- USB Type-A and Type-C (5 V) inputs

REAL TIME INFORMATION

- Touchscreen, 12"
- MCTS – Magni Combi Touch System on-board software
- Automatic RFID tools recognition system
- LMI – Load Moment Indicator
- LLD – Live Load Diagram
- Onboard and remote integrated diagnostics
- Reversing camera with image integrated in the MCTS

TECHNICAL SPECIFICATIONS

- Q-Fit standard
- Provision for platform
- Advanced three-line CAN BUS system
- Automatic levelling system for outriggers
- Automatic front and rear wheel alignment
- High-precision turret rotation motor by Liebherr
- Automatic parking brake
- Mechanical battery cut-off in engine compartment
- Electrical system: 24 V – IP67

SERVICE

- MyMagni by Trackunit connectivity system (2 years)
- Warranty: 24 months/2,000 hours