

TH

4,5.19 P



CONSTRUCTION



LOGISTICS



EVENTS AND  
FILM



TH  
4,5.19 P



**CAB**

Best-in-class  
safety and visibility



**PERFORMANCE**

Unrivalled lifting  
performance



**LOAD LIVE DIAGRAM**

Two real-time dynamic  
load charts

# TH 4,5.19 P

## DIMENSIONS (ft and in)

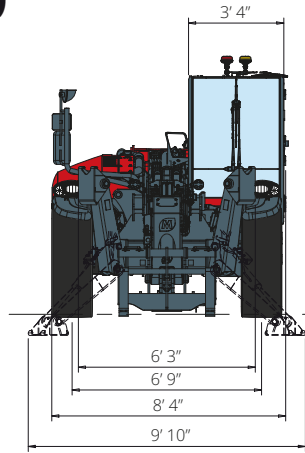

**FRONT**  
view

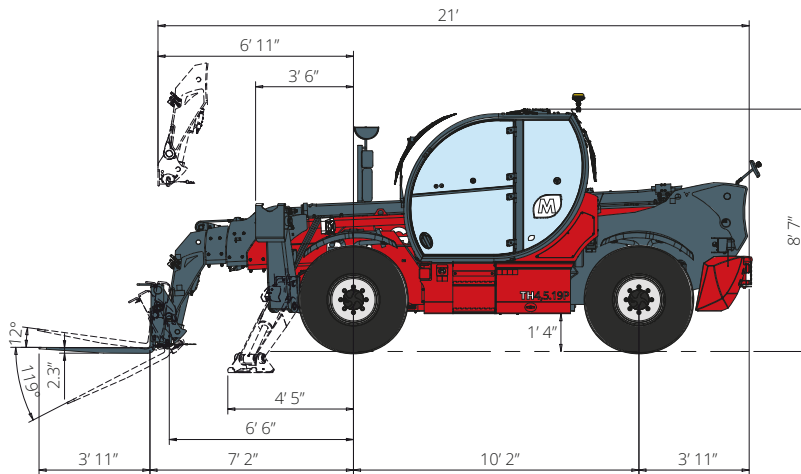

**SIDE**  
view

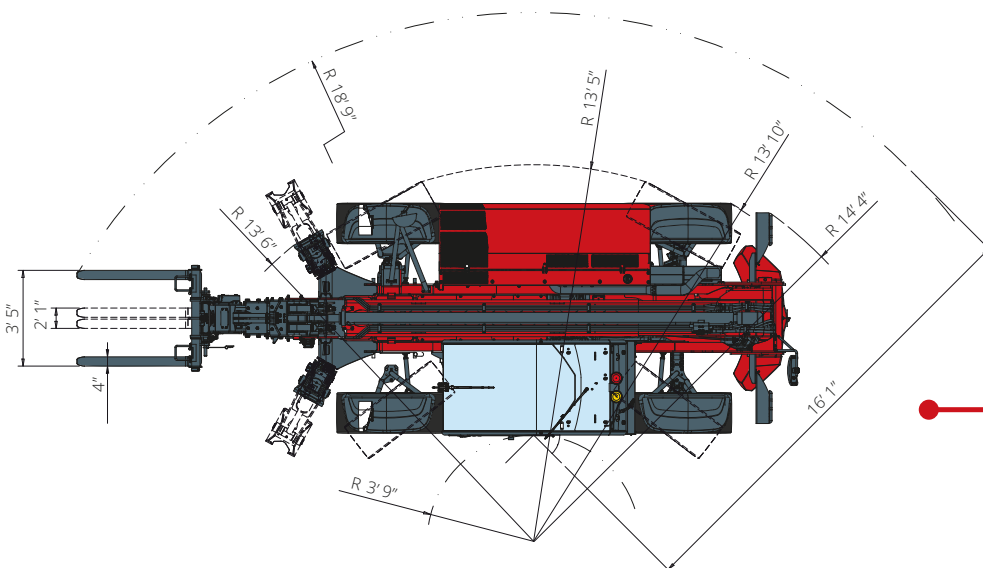

**TOP**  
view

Load chart with  
**FULLY EXTENDED STABILIZERS**

ATT-08-014

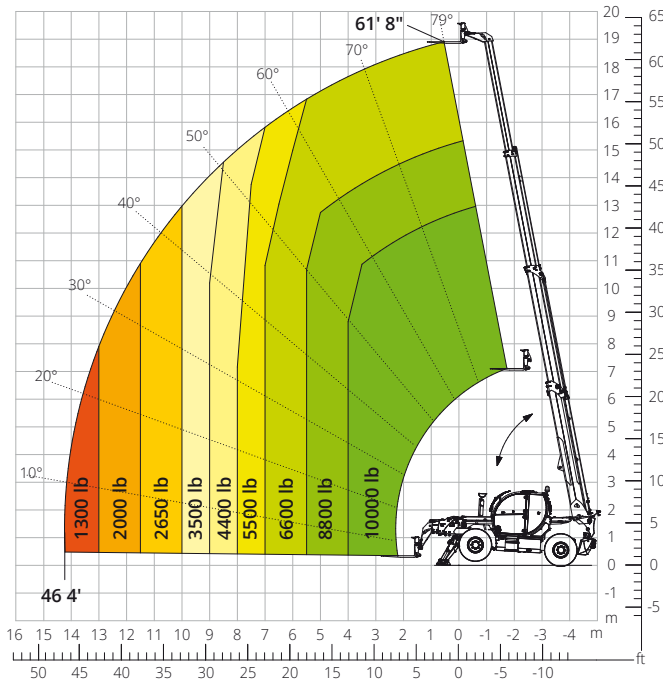

Load chart  
**FRONT ATTACHMENT ON TIRES**

ATT-08-014

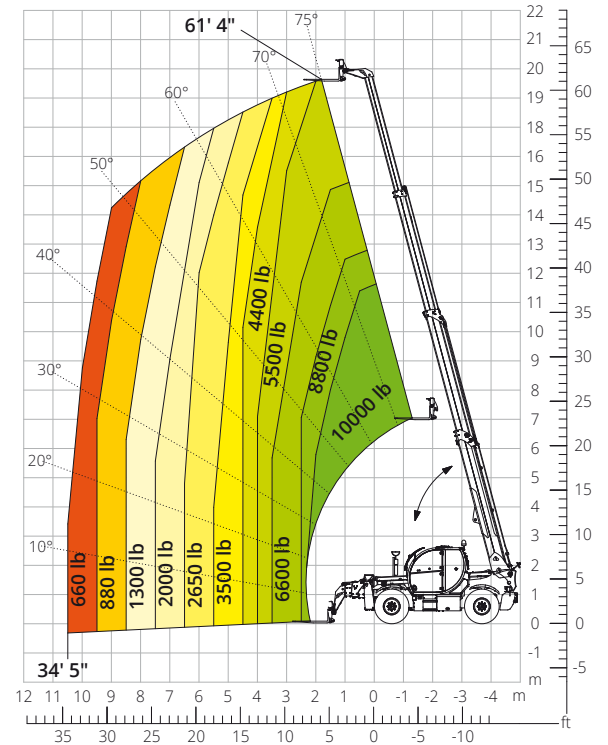

Load chart with  
**WINCH, 7,700 lb**

ATT-02-022

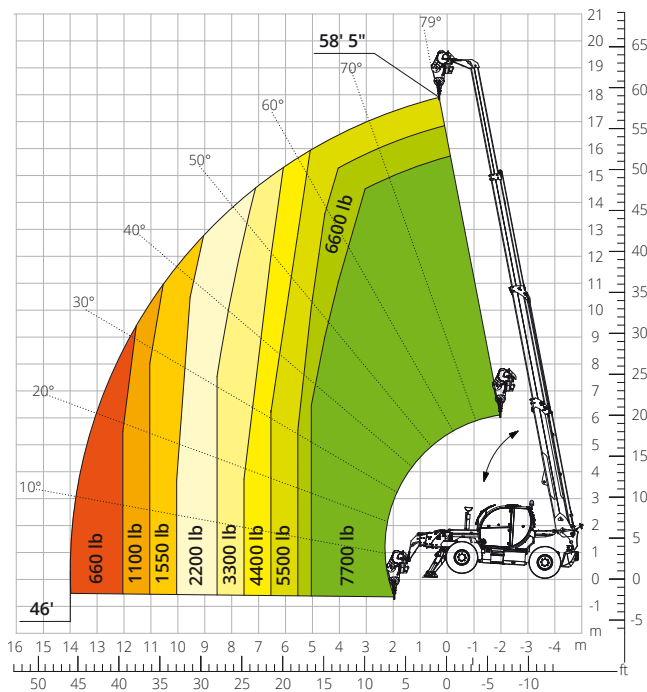

Load chart with  
**WINCH, 11,000 lb**

ATT-02-019

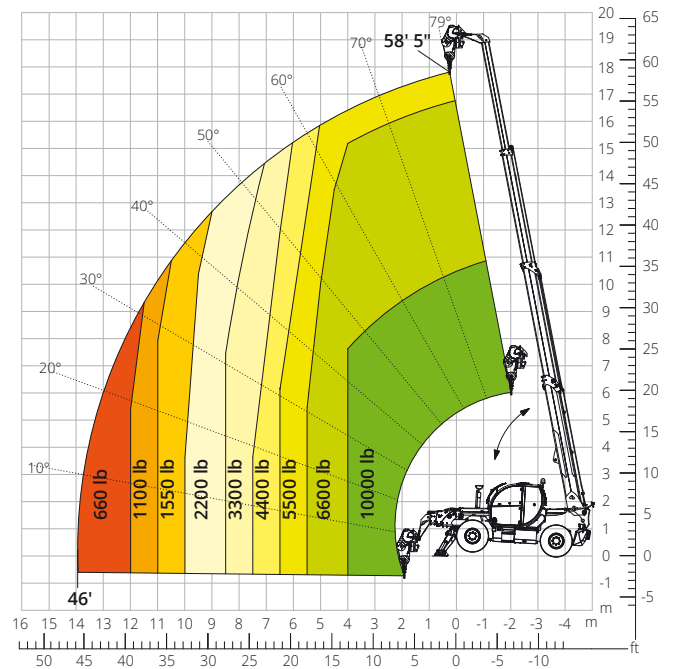



Load chart with  
**JIB WITH WINCH, 3,300 lb**

ATT-04-011

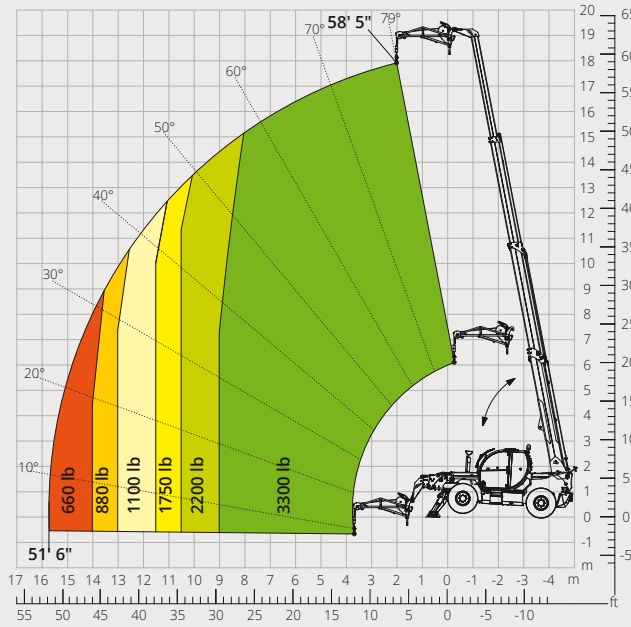

Load chart with  
**JIB WITH WINCH, 4,400 lb**

ATT-04-015

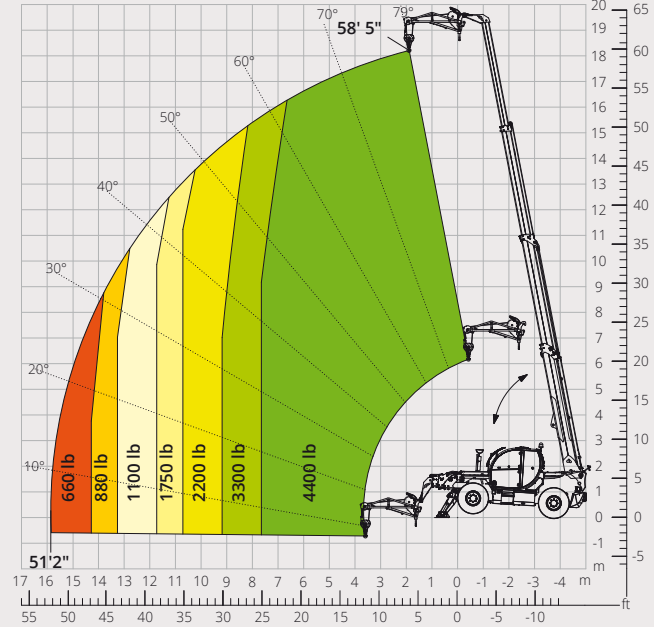

Load chart with  
**JIB 4,400 lb**

ATT-04-013

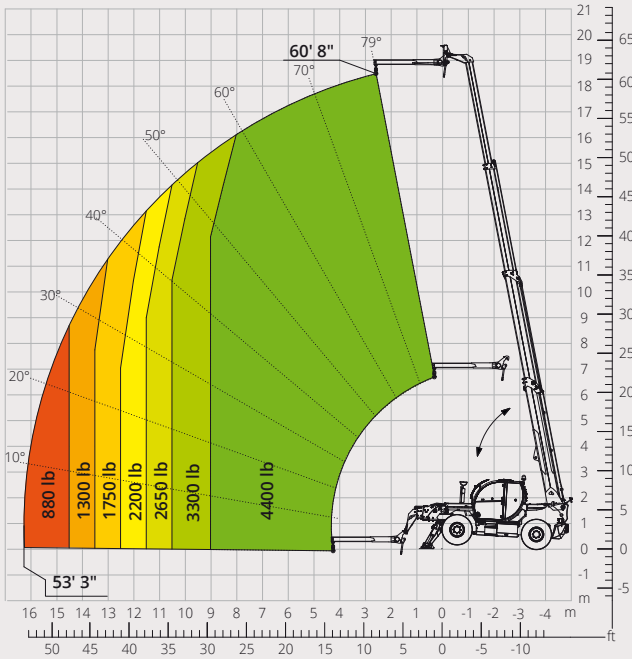

Load chart with  
**HOOK, 11,000 lb**

ATT-05-001

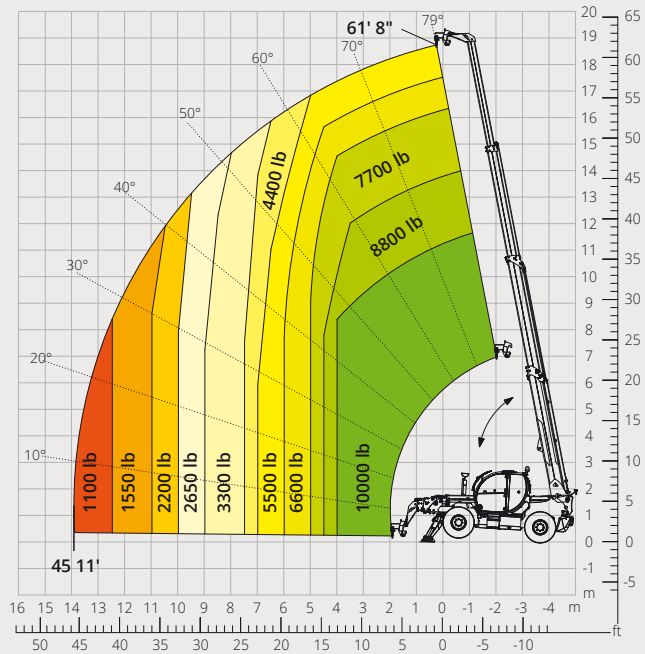

Load chart with  
**ROTATING EXTENDABLE PLATFORM, 2,200 lb**  
ATT-01-016

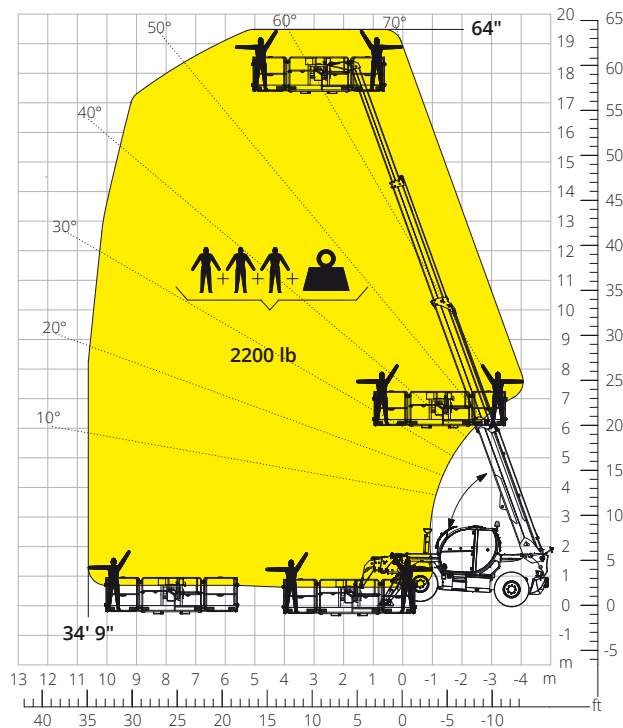

Load chart with  
**ROTATING NON-EXTENDABLE PLATFORM, 550 lb**  
ATT-01-003

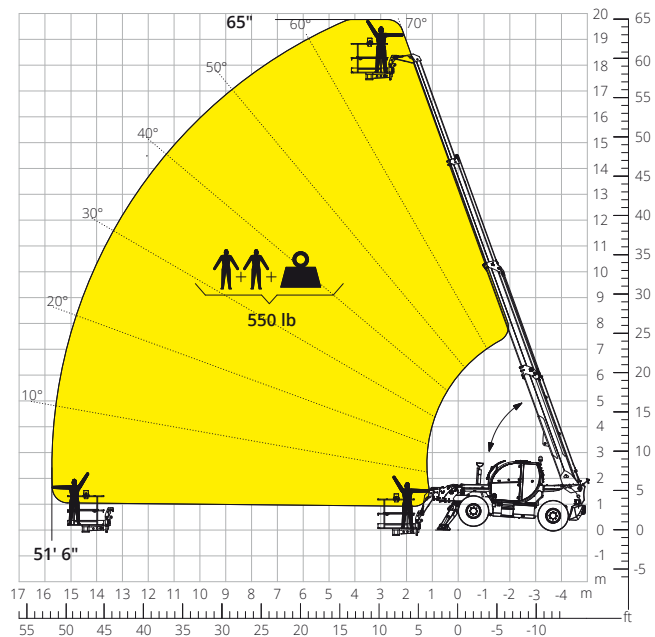

Load chart with  
**FIXED PLATFORM, 550 lb**  
AT-01-001

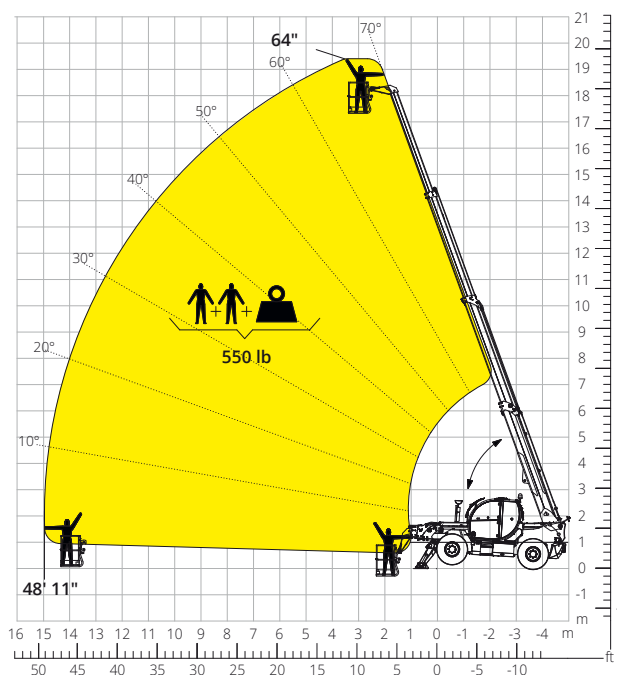

Load chart with  
**PLATFORM, 1,000 lb, FOR MINES**  
ATT-01-027

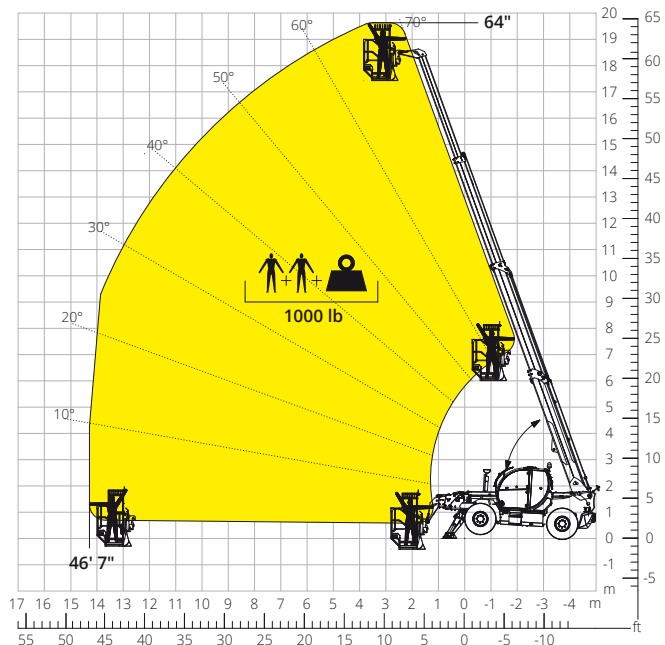

<b>Machine model</b>	Telescopic handler	TH 4,5.19 P	
	Maximum lifting capacity	10,000 lb	
	Maximum lifting height	61' 8"	
	Maximum reach	46' 4"	
<b>Stabilizers</b>	Type	Pivoting	
<b>Engine</b>	Model	<b>Deutz TCD 3,6 L4 EDG - Stage IIIA</b>	<b>Deutz TCD 3,6 L4 Stage V</b>
	Rated power	74.4 kW (101.2 hp) at 2,200 rpm	
	Maximum torque	302 lb/ft at 1,600 rpm	
	Displacement	3.6 l	
	Cylinders	4 in line	
	Engine configuration	Turbocharged direct injection diesel	
	Cooling system	Water – intercooler	
<b>Transmission</b>	Type	Hydrostatic	
	Maximum pressure	530 bar	
	Gear box	Dropbox, 2 speeds forward-reverse	
<b>Axles and brakes</b>	Type	Axles with planetary gearboxes	
	Front axle	Oscillating and steering with levelling, +/-8°	
	Rear axle	Oscillating and steering with hydraulic lock	
	No. of driving/steering wheels	4WD - 4WS	
	Steering mode	Frontal/Concentric/Crab	
	Service brake	Wet multi-disk on front and rear axle	
	Parking brake	Hydraulic with negative action on front axle	
<b>Performance</b>	Tyres dimensions	445/65 R22.5	
	Max. travel speed	21 mph	
	Gradeability (unladen)	58%	
	Turning radius (end of forks)	18'10"	
<b>Weights</b>	Total unladen*	28,000 lb	
	Front axle unladen (boom retracted and lowered)*	12,350 lb	
	Rear axle unladen (boom retracted and lowered)*	15,650 lb	
<b>Tank and system capacities</b>	Fuel tank	52.8 U.S. gal	
	AdBlue	2.64 U.S. gal	
	Hydraulic oil tank	24.6 U.S. gal	
	Engine oil tank	2.4 U.S. gal	
	Cooling liquid	5.3 U.S. gal	
<b>Hydraulic circuit for movements</b>	Circuit type	Load sensing	
	Service pump	Variable displacement	
	Max. hydraulic flow rate	120 l/min	
	Max. boom head flow rate	75 l/min	
	Max. operating system pressure	350 bar	
	Controls for boom movements	SIL 2 electro-proportional valve	
	Movements control	1 joystick with integrated manoeuvre enable	
<b>Standard met</b>	2006/42/EC: EU Machinery Directive		
	2016/1628: EU Regulation on the emissions of stage V engines		
	EN 1459-X: Relating to standards on the safety requirements for variable reach machines		
	EN 280-1/EN 280-2: standards relating to mobile elevating work platforms (if available)		
	ROPS/level 2 FOPS: relating to the standards for protective structures		

*The data given in this brochure are provided for information purposes and are subject to change without prior notice.  
All images are purely guideline and might not give an exact representation of the product.  
\*the stated weight refers to the vehicle unladen with standard equipment and may vary depending on the chosen configuration.*

## The standard machine configuration includes:

### CAB

- Comfort seat with adjustable headrest
- Adjustable steering column
- Analogue joypad
- Adjustable sunblind
- Heating
- Air conditioning
- FM/AM radio with USB and Bluetooth connectivity
- Ambient LED lights
- USB Type-A and Type-C (5 V) inputs

### REAL TIME INFORMATION

- Touchscreen, 7"
- MCTS – Magni Combi Touch System on-board software
- Automatic RFID tools recognition system
- LMI – Load Moment Indicator
- LLD – Live Load Diagram
- Onboard and remote integrated diagnostics

### TECHNICAL SPECIFICATIONS

- Q-Fit standard
- Provision for platform
- Advanced three-line CAN BUS system
- Automatic levelling system for outriggers
- Automatic front and rear wheel alignment
- Automatic parking brake
- Mechanical battery cut-off in engine compartment
- Electrical system: 24 V – IP67

### SERVICE

- Warranty: 24 months/2,000 hours