

# HTH 10.10



MINING &  
QUARRYING



HEAVY  
LOGISTICS



DEFENCE



# HTH 10.10

## DIMENSIONS (mm)

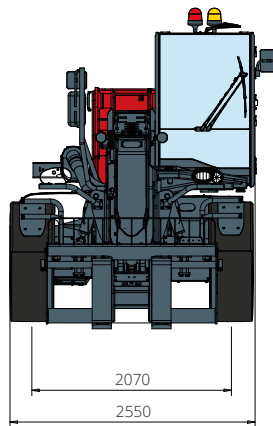

**FRONT**  
view

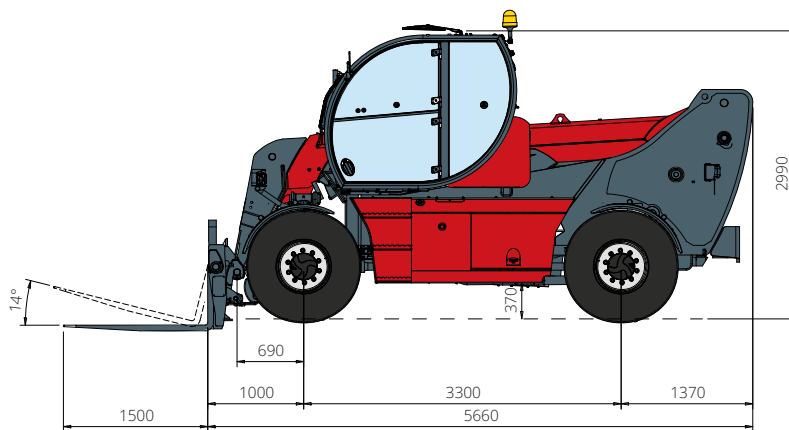

**SIDE**  
view

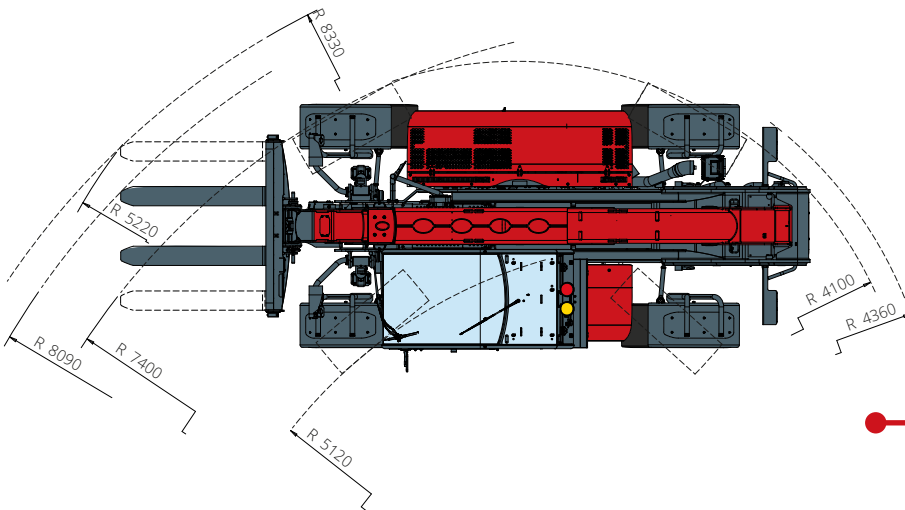

**TOP**  
view

Load chart  
**FRONT ATTACHMENT ON TYRES**  
**(WORLD NOT AUS)**

ATT-03-018/ ATT-03-019

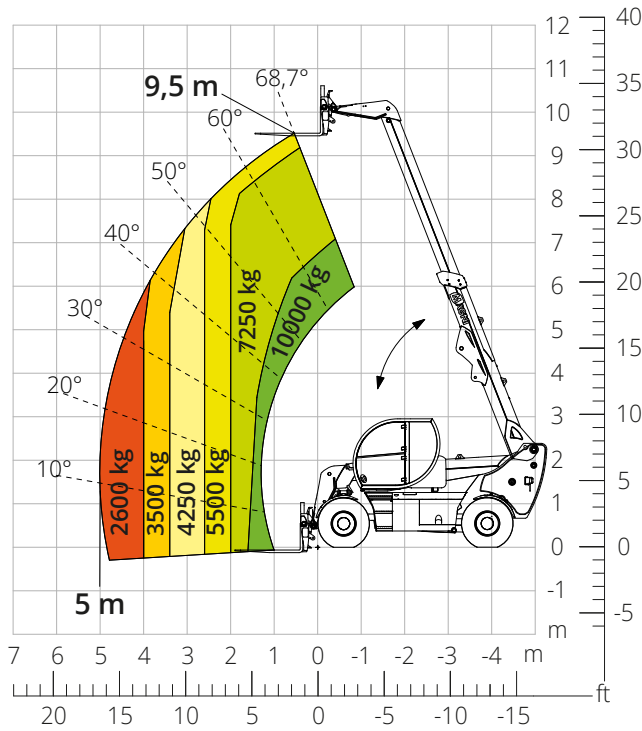

Load chart  
**FRONT ATTACHMENT ON TYRES (AUS)**

ATT-03-018/ ATT-03-019

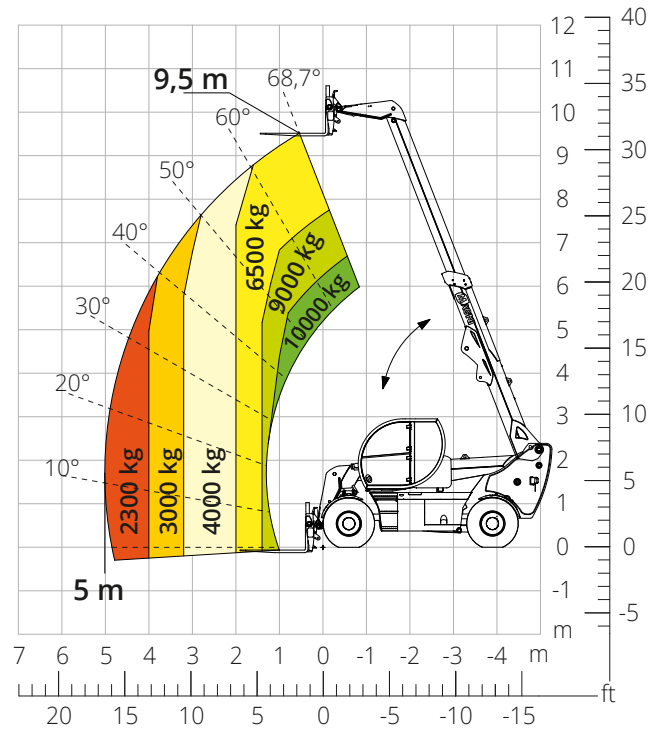

Load chart with  
**TYRE HANDLER, 2,500 kg**

ATT-06-003

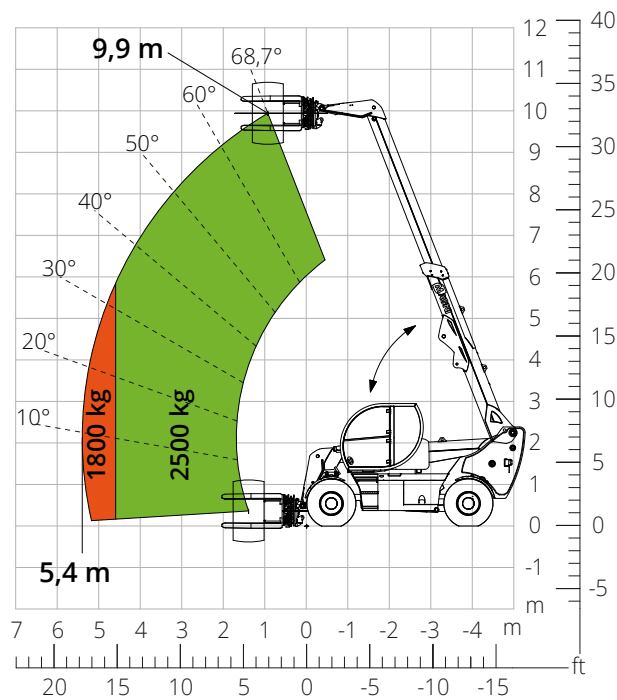

Load chart with  
**TYRE HANDLER, 3,500 kg**

ATT-06-004

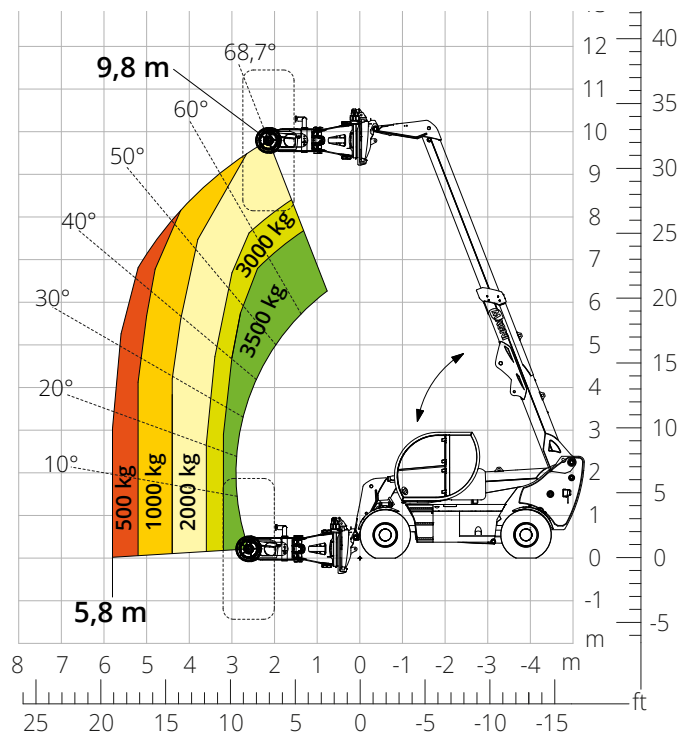

Load chart with  
**HOOK, 10,000 kg (WORLD NOT AUS)**  
ATT-05-005

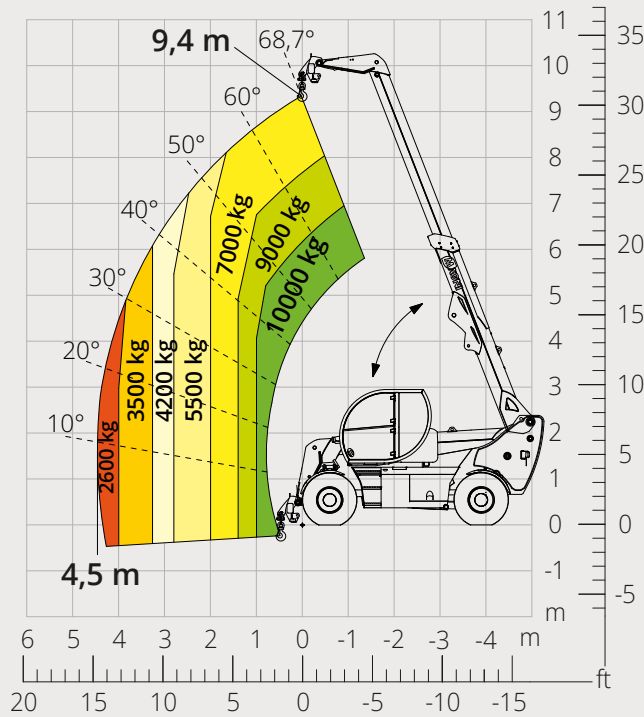

Load chart with  
**WINCH, 6,000 kg**  
ATT-02-004

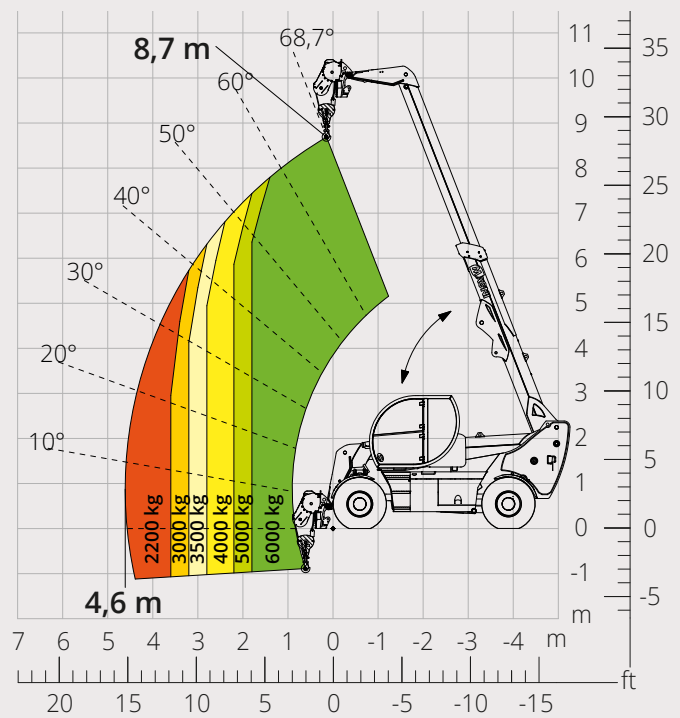

Load chart with  
**JIB, 3,000 kg**  
ATT-04-019

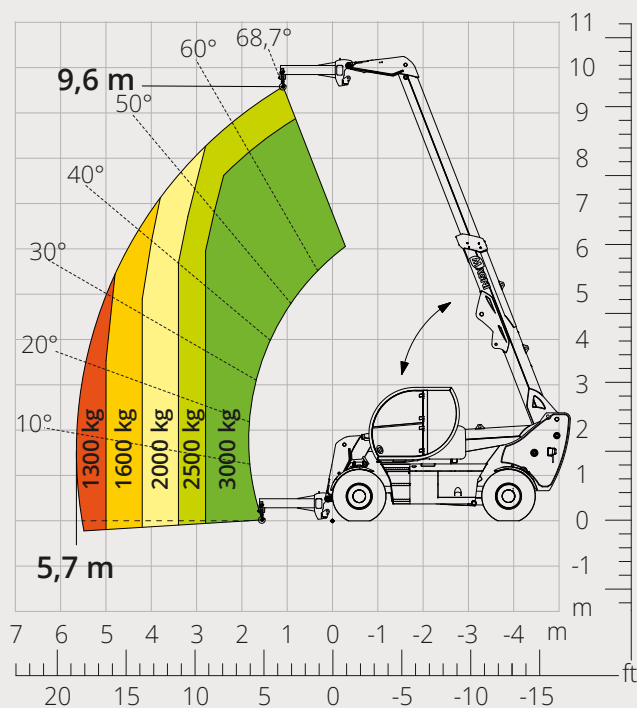

Load chart with  
**PLATFORM, 450 kg, FOR MINES**  
ATT-01-027

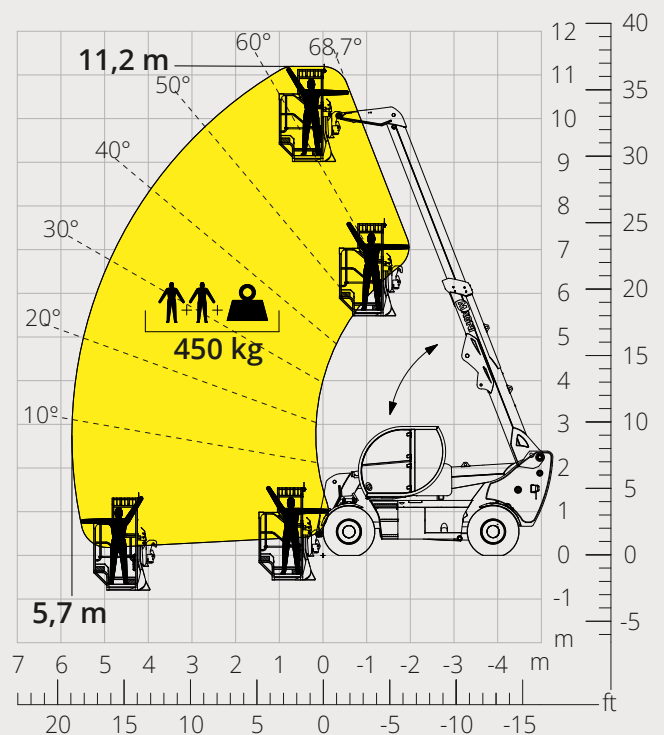

<b>Machine model</b>	Telescopic handler	HTH 10.10
	Maximum lifting capacity	10,000 kg
	Maximum lifting height	9.50 m
	Maximum reach	5.00 m
<b>Engine</b>	Model	<b>Deutz TCD 3,6 L4-Stage V</b>   <b>Deutz TCD 3,6 L4 -Stage IIIA</b>
	Rated power	100 kW (136 hp) at 2,200 rpm
	Maximum torque	500 Nm at 1,600 rpm
	Displacement	3,62 l
	Cylinders	4 in line
	Engine type	Turbocharged direct injection common rail diesel
	Cooling system	Water - intercooler
<b>Transmission</b>	Type	Hydrostatic
	Maximum pressure	450 bar
	Gearbox	Dropbox, 2 speeds forward-reverse
<b>Axles and brakes</b>	Type	Heavy-duty with planetary gearboxes
	Front axle	Steering and levelling
	Rear axle	Steering and oscillating
	No. of driving - steering wheels	4WD - 4WS
	Steering mode	Frontal/Concentric/Crab
	Service brake	Servo-assisted pedal, acting on front and rear wheels
	Parking brake	Hydraulic with negative action on front and rear axles
	Tyre sizes	18 R22.5
<b>Performance</b>	Max. travel speed	40 km/h
	Gradeability (unladen)	63%
	Turning radius	4,100 mm
<b>Weights</b>	Total unladen*	13,200 kg
	Front axle unladen (boom retracted and lowered)*	4,700 kg
	Rear axle unladen (boom retracted and lowered)*	8,500 kg
<b>Tank and system capacities</b>	Diesel fuel	195 l
	AdBlue	10 l
	Hydraulic fluid	190 l
	Engine oil	9 l
	Coolant	20 l
<b>Hydraulic circuit for movements</b>	Circuit type	Load sensing
	Service pump	Variable displacement
	Max. hydraulic flow rate	156 l/min
	Max. boom head flow rate	75 l/min
	Max. working pressure	400 bar
	Distributor for boom movements	Proportional hydraulic distributor
	Movements control	Multifunction electro-proportional joystick
<b>Standards met</b>	2006/42/EC: EU Machinery Directive	
	2016/1628: EU Regulation on the emissions of stage V engines	
	EN 1459-X: Relating to standards on the safety requirements for variable reach machines	
	EN 280/EN 280-1/EN 280-2: standards relating to mobile elevating work platforms (if available)	
	ROPS/level 2 FOPS: relating to the standards for protective structures	

The data given in this brochure are provided for information purposes and are subject to change without prior notice.

All images are purely guideline and might not give an exact representation of the product.

\*the stated weight refers to the vehicle unladen with standard equipment and may vary depending on the chosen configuration.

The standard machine configuration includes:

## CAB

- Comfort seat
- Adjustable steering column
- Analogue joypad
- Heating
- Air conditioning
- FM/AM radio with USB and Bluetooth connectivity
- USB Type-A (5 V) inputs

## REAL TIME INFORMATION

- Touchscreen, 7"
- MCTS – Magni Combi Touch System on-board software
- Automatic RFID tools recognition system
- LMI – Load Moment Indicator
- Onboard and remote integrated diagnostics

## TECHNICAL SPECIFICATIONS

- Q-Fit standard
- Provision for platform
- Two-line CAN BUS system
- Automatic front and rear wheel alignment
- Automatic parking brake
- Mechanical battery cut-off in engine compartment
- Electrical system: 24 V – IP67

## SERVICE

- MyMagni by Trackunit connectivity system (2 years)
- Warranty: 24 months/2,000 hours