



HTH

16.10



MINING &
QUARRYING



HEAVY
LOGISTICS



DEFENCE

HTH 16.10

DIMENSIONS (mm)

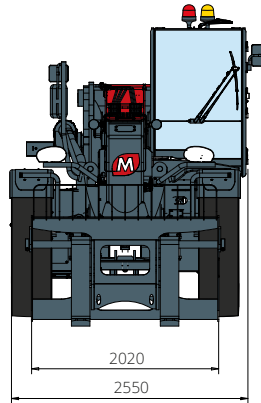

FRONT
view

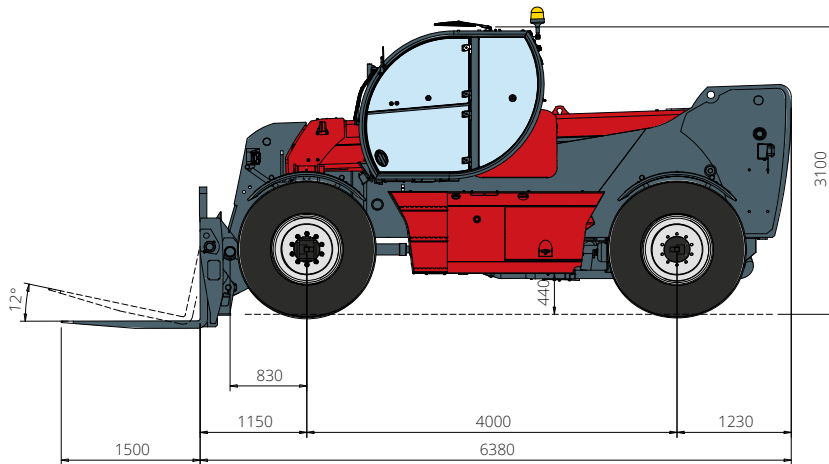

SIDE
view

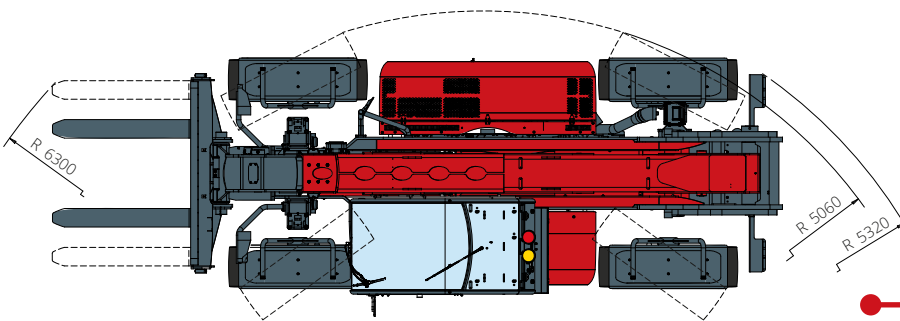

TOP
view

Load chart
**FRONT ATTACHMENT ON TYRES
(WORLD NOT AUS)**

ATT-03-022/ ATT-03-023

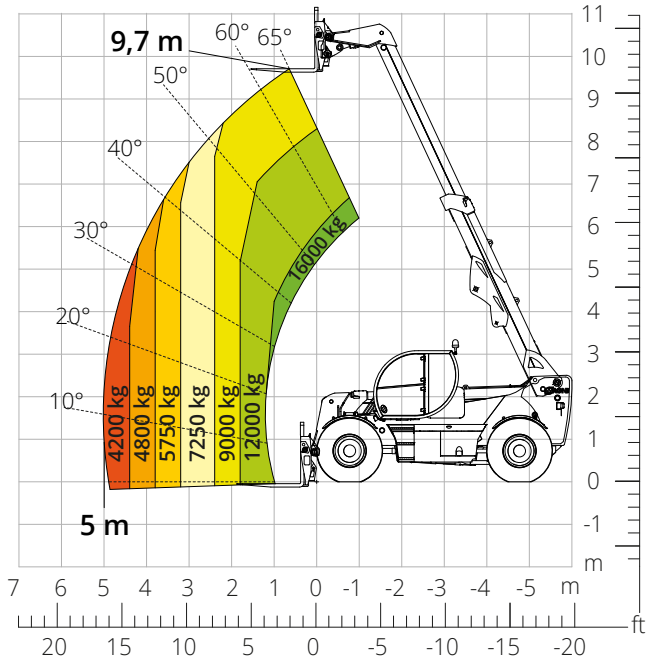

Load chart
FRONT ATTACHMENT ON TYRES (AUS)

ATT-03-022/ ATT-03-023

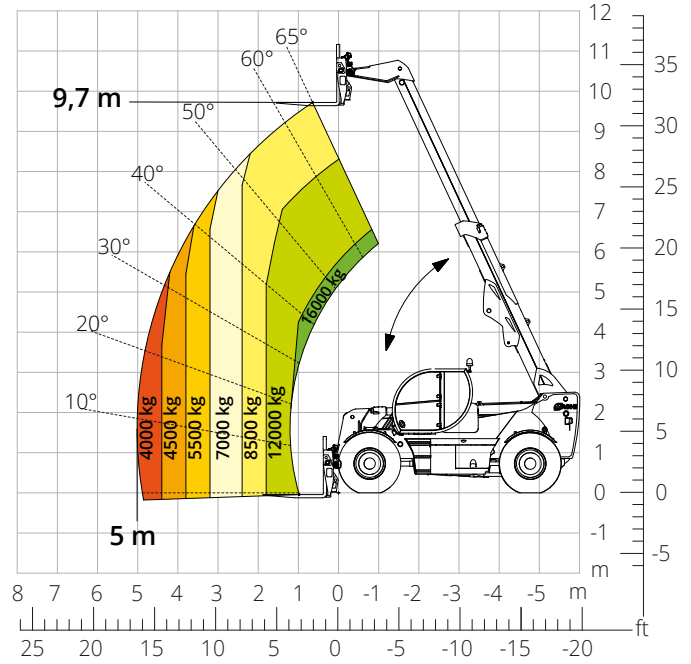

Load chart with
**FORKS WITH POSITIONER
AND SIDE SHIFT, 16,000 kg**

ATT-03-024

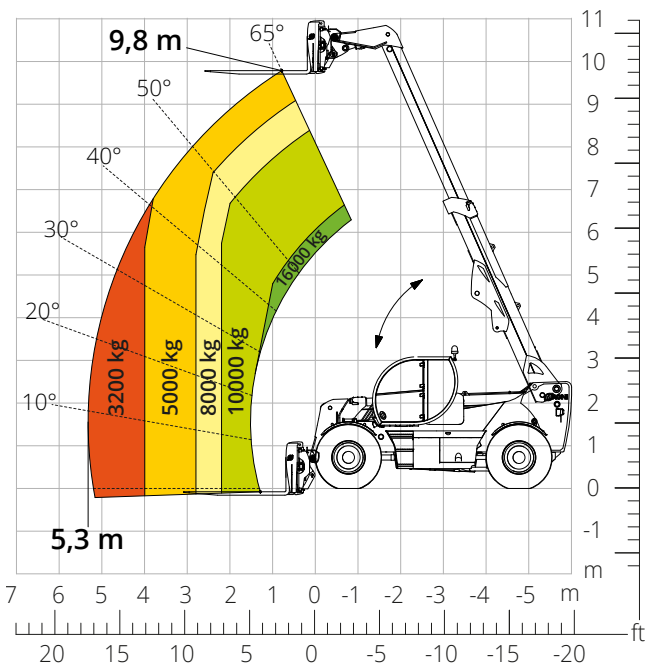

Load chart with
FORKS WITH POSITIONER, 16,000 kg

ATT-03-025

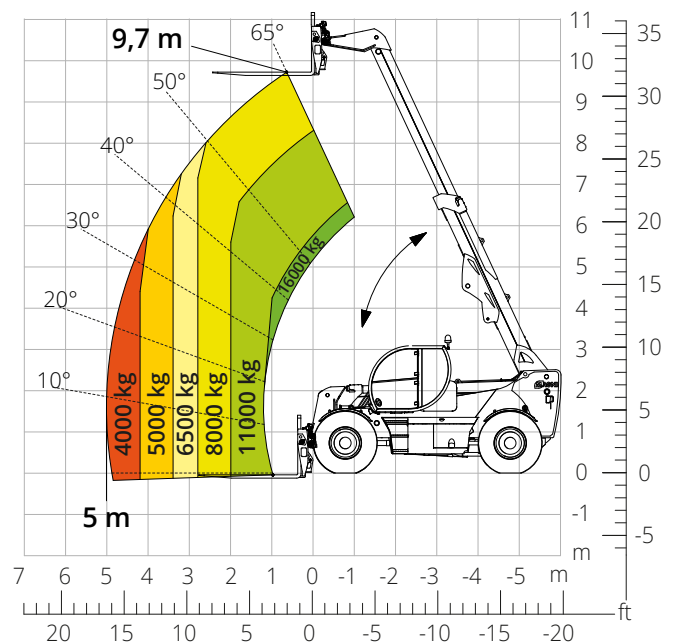

Load chart with
WINCH, 16,000 kg
ATT-02-008

Load chart with
HOOK, 16,000 kg
ATT-05-007

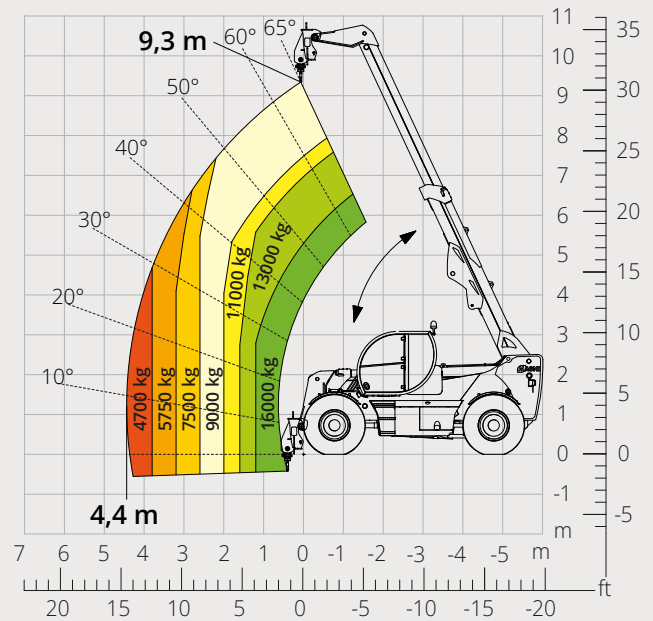
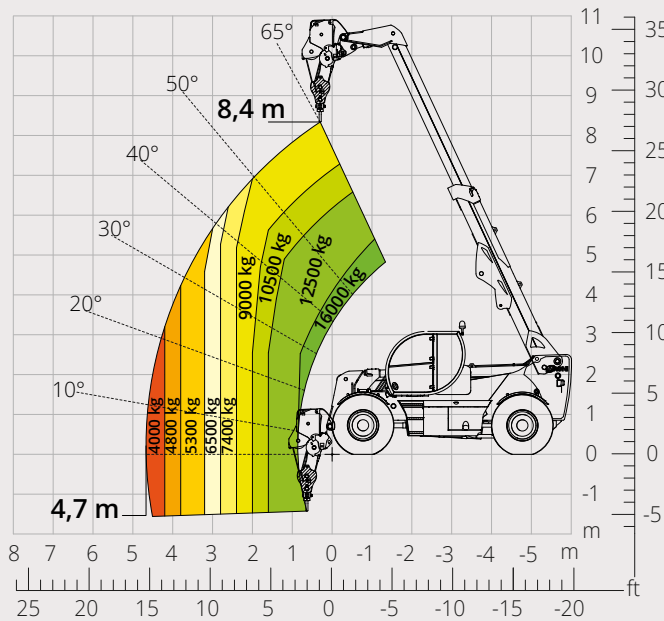

Load chart with
JIB, 8,000 kg
ATT-04-026

Load chart with
TYRE HANDLER, 8,000 kg
ATT-06-006

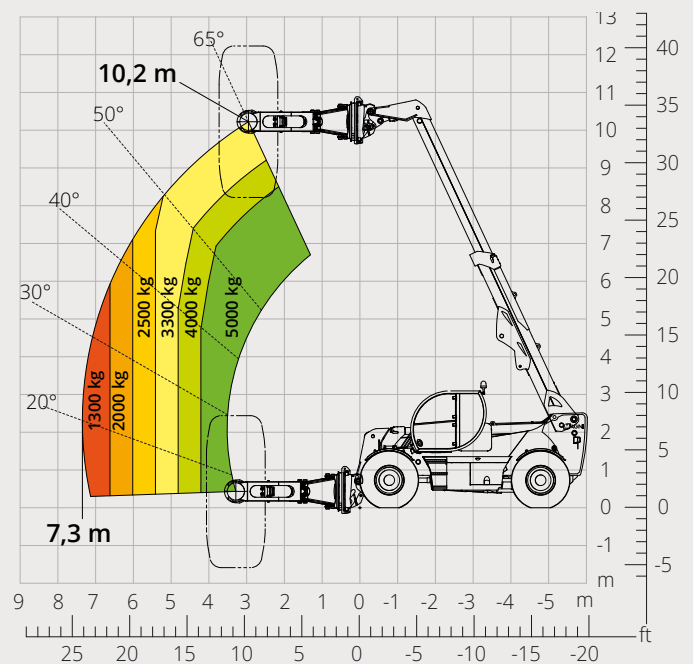
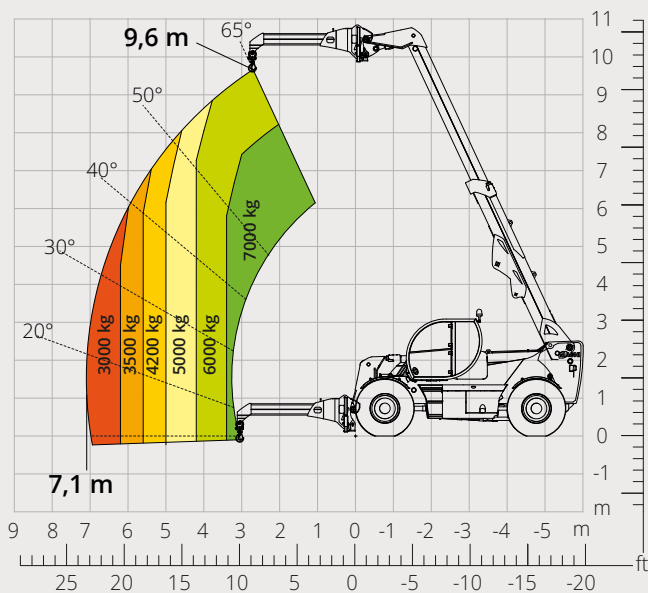

Machine model	Telescopic handler	HTH 16.10	
	Maximum lifting capacity	16,000 kg	
	Maximum lifting height	9.70 m	
	Maximum reach	5.00 m	
Engine	Model	Volvo TAD582 VE-Stage V	Volvo TAD552 VE-Stage IIIA
	Rated power	160 kW (218 hp) at 2,300 rpm	160 kW (218 hp) at 2,200 rpm
	Maximum torque	925 Nm at 1,380 rpm	910 Nm at 1,450 rpm
	Displacement	5.13 l	
	Cylinders	4 in line	
	Engine type	Turbocharged direct injection common rail diesel	
	Cooling system	Water – intercooler	
	Transmission	Type	Hydrostatic
Maximum pressure		450 bar	
Gearbox		Dropbox, 2 speeds forward-reverse	
Type		Heavy-duty with planetary gearboxes	
Axles and brakes	Front axle	Steering and levelling	
	Rear axle	Steering and oscillating	
	No. of driving - steering wheels	4WD - 4WS	
	Steering mode	Frontal/Concentric/Crab	
	Service brake	Servo-assisted pedal, acting on front and rear wheels	
	Parking brake	Hydraulic with negative action on front and rear axles	
	Tyre sizes	16,00- R 25	
	Performance	Max. travel speed	25 km/h
Gradeability (unladen)		56%	
Turning radius		5,060 mm	
Total unladen*		20,500 kg	
Weights	Front axle unladen (boom retracted and lowered)*	9,000 kg	
	Rear axle unladen (boom retracted and lowered)*	11,500 kg	
Tank and system capacities	Diesel fuel	200 l	
	AdBlue	40 l	
	Hydraulic fluid	210 l	
	Engine oil	16 l	
Hydraulic circuit for movements	Coolant	47 l	
	Circuit type	Load sensing	
	Service pump	Variable displacement	
	Max. hydraulic flow rate	132 l/min	
	Max. boom head flow rate	100 l/min	
	Max. working pressure	350 bar	
	Distributor for boom movements	Proportional hydraulic distributor	
	Movements control	Multifunction electro-proportional joystick	
Standards met	2006/42/EC: EU Machinery Directive		
	2016/1628: EU Regulation on the emissions of stage V engines		
	EN 1459-X: Relating to standards on the safety requirements for variable reach machines		
	EN 280/EN 280-1/EN 280-2: standards relating to mobile elevating work platforms (if available)		
	ROPS/level 2 FOPS: relating to the standards for protective structures		

The data given in this brochure are provided for information purposes and are subject to change without prior notice.

All images are purely guideline and might not give an exact representation of the product.

**the stated weight refers to the vehicle unladen with standard equipment and may vary depending on the chosen configuration.*

The standard machine configuration includes:

CAB

- Comfort seat
- Adjustable steering column
- Analogue joypad
- Heating
- Air conditioning
- FM/AM radio with USB and Bluetooth connectivity
- USB Type-A (5 V) inputs

REAL TIME INFORMATION

- Touchscreen, 7"
- MCTS – Magni Combi Touch System on-board software
- Automatic RFID tools recognition system
- LMI – Load Moment Indicator
- Onboard and remote integrated diagnostics

TECHNICAL SPECIFICATIONS

- Q-Fit Heavy-Duty
- Two-line CAN BUS system
- Automatic front and rear wheel alignment
- Automatic parking brake
- Mechanical battery cut-off in engine compartment
- Electrical system: 24 V – IP67

SERVICE

- MyMagni by Trackunit connectivity system (2 years)
- Warranty: 24 months/2,000 hours