

**IN**
OUT
4WD
4WS

ETB22RT

Telescopic boom lifts



STANDARD EQUIPMENT

- Oscillating front axle
- Two travel speeds
- Four-wheel steering
- Four-wheel drive
- 360° rotation (continuous)
- Special construction equipment-grade integral driveshaft
- Proportional controls
- Thumb rocker steering
- Flashing light
- Non-marking tyres
- Horn
- Hour counter
- Harsh environment kits
- 12V DC Auxiliary power

BATTERY

- Lithium battery - Maintenance-free
- Battery capacity: 80 V/420 Ah
- Single- and three-phase, 380 V & 220 V
- Recharge time, 0 - 100% (hours)* 5.5

BASKET

- Self-levelling
- Rotation +/-90°
- Schuko power socket 16A/250 V

SAFETY

- Drive enable system
- Platform load moment indicator
- On-board diagnostics system
- Emergency lowering system
- Tilt indicator with alarm
- Crushing protection

**CONSTRUCTION****LOGISTICS**

LOAD CHART

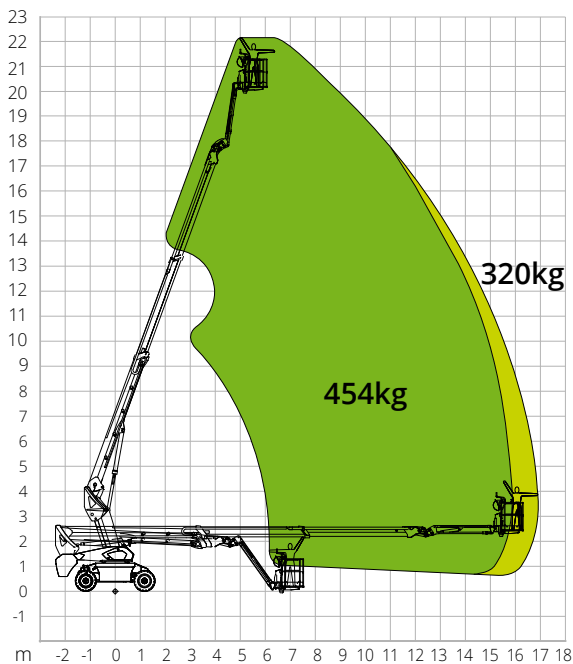

DIMENSIONS

Platform length (transport)	7.25 m
Platform width (transport)	2.50 m
Platform width (axle expanded)	-
Platform width (axle retracted)	-
Platform height (transport)	2.70 m
Wheelbase	B 2.40 m
Wheelbase (axle extended)	-
Wheelbase (axle retracted)	-
Tailswing	1.19 m
Ground clearance	A 0.28 m

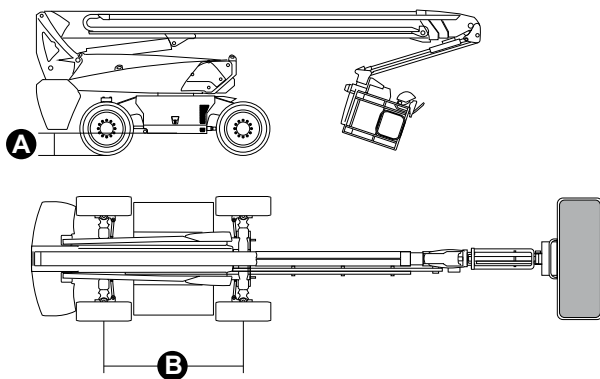

STANDARDS COMPLIANCE: EN 280-1, ANSI/SAIA A92.20

The data given in this brochure are provided for information purposes and are subject to change without prior notice. All images are purely guideline and might not give an exact representation of the product.

ETB22RT

Technical data

Max. working height	22.60 m
Max. basket height	20.60 m
Max. reach	17.28 m
Turning radius (outside)	2.62 m
Turning radius (inside)	1.65 m
Basket width	0.91 m
Basket length	2.44 m
Basket rotation	180°
Jib type	Standard
Jib length	2.31 m
Jib Vertical Rotation	135°
Jib travel angle	-
Auxiliary power	12V DC

Performance

Platform max. load capacity	320/454 kg
Max. occupants	3
Max. gradeability (stowed)	30%
Max. working slope	X-5°/Y-5°
Max. wind speed	12.5 m/s
Travel speed (closed config.)	6.0 km/h
Travel speed (working config.)	1.1 km/h
Turret rotation (continuous)	360°

Engine

Travel power	54V AC/18 kW
Drive pump	-
Hydraulic tank capacity	165 l
Transmission	Hydrostatic

Specific characteristics

Tyres	315/55D20
Battery type	Lithium battery - Maintenance-free
Battery capacity	420Ah/80V
Charger	-
Charger type	Single- and three-phase, 380 V & 220 V
Recharge time, 0 - 100% (hours)*	5.5
Lifting motors	-
Total weight	13,200 kg

*Nominal. The actual value depends on weather and usage factors