



DTB16RT

This telescopic platform has a very low centre of gravity, resulting in excellent stability and outstanding lifting performance. It is equipped with a fuel-saving diesel engine and 4 drive wheels integrated into the axle for improved offroad performance.

STANDARD EQUIPMENT

- Proportional controls
- Thumb rocker steering
- Flashing light
- Horn
- Hour counter
- Harsh Environment Kits
- 12V DC Auxiliary Power

PERFORMANCE

- Front oscillating axles to match the terrain irregularities granting optimal adherence to the ground
- 2 Wheels Steering
- Four-wheel drive
- Positive traction four wheel drive
- 360° rotation (continuous)
- Integral Integrated Special Drive Axle

ENGINE

- Stage V engine (Stage IIIA available upon request)
- Auto Engine Fault Shutdown
- Anti-reverse Engine Device
- Anti-restart Engine Protection
- Hydraulic oil radiator

BASKET

- Self levelling platform
- Rotating basket +/-90°
- Power to platform

SAFETY

- Drive enable system
- Platform load sense system
- On-board diagnostics system
- Tilt indicator with alarm
- Crushing protection
- Emergency lowering system

STANDARD EQUIPMENT



Construction



Large Events



Aircraft maintenance
Ship repair



Plant Service



Oil & gas



Restoration

DTB16RT

Max. working height	16.22 m
Max. basket height	14.22 m
Max. reach	9.40 m
Max. platform load capacity	250 kg
Max. Occupants	2
Max. gradeability (stowed)	40%
Max. working slope	X-5°/Y-5°
Max. wind speed	12.5 m/s
Turning radius (outside)	4.49 m
Turning radius (inside)	2.92 m
Turret rotation (continuous)	360°
Jib type	Regular
Jib length	1.5 m
Jib movement	-
Jib vertical rotation	132°
Basket width	0.79 m
Basket length	2.92 m
Basket rotation	180°
Total weight	6,130 kg
Travel speed (closed config.)	6.0 km/h
Travel speed (working config.)	1.1 km/h
Tyres	315/55D20
Engine	Kubota D1105/18kW
Diesel tank capacity	115 l
Hydraulic tank capacity	145 l
Electrical system	-
Emergency power system	-
Transmission	Hydrostatic

LOAD CHART

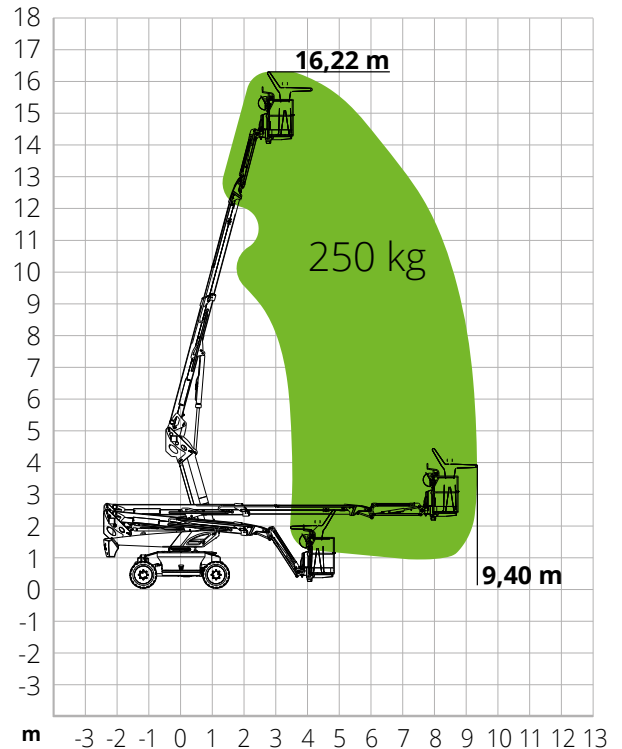

DIMENSIONS

A Platform length	7.37 m
Platform length (transport)	5.49 m
B Platform width	5.49 m
Platform width (transport)	2.33 m
C Platform height	2.49 m
Platform height (transport)	2.60 m
E Wheelbase	2.30 m
Tailswing	1.24 m
D Ground clearance	0.31 m

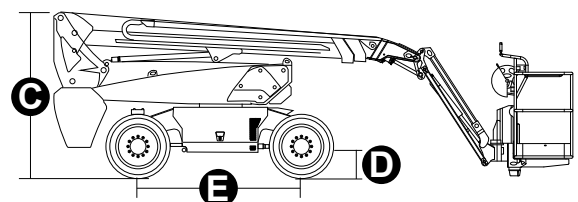
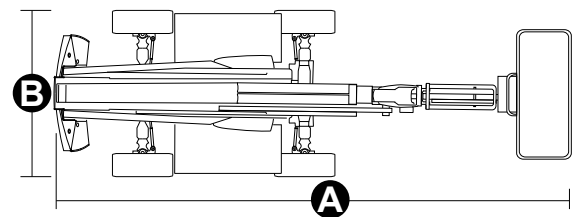

STANDARDS COMPLIANCE: EN 280, ANSI/SAIA A92.20

#LIFTDIFFERENT

www.magnith.com



The data in this brochure are provided for the purposes of information and subject to change without notice.