



ETB18RT

This telescopic platform is equipped with an integrated high capacity battery pack. As a result, it is silent and emissions free, the ideal solution for working in enclosed spaces. It is also equipped with 4 drive wheels for greater stability on any surface. The boom folds for transport so that the vehicle can be shipped in a container.

STANDARD EQUIPMENT

- Proportional controls
- Thumb rocker steering
- Flashing light
- Horn
- Hour counter
- Harsh Environment Kits
- 12V DC Auxiliary Power

PERFORMANCE

- Front oscillating axles to match the terrain irregularities granting optimal adherence to the ground
- 2 Wheels Steering
- Four-wheel drive
- Positive traction four wheel drive
- 360° rotation (continuous)
- Integral Integrated Special Drive Axle

BASKET

- Self levelling platform
- Rotating basket +/-90°
- Power to platform

SAFETY

- Drive enable system
- Platform load sense system
- On-board diagnostics system
- Tilt indicator with alarm
- Crushing protection
- Emergency lowering system

BATTERY

- TIANNENG - Lead-acid battery
- Powersource : 48V/375Ah
- Charger : 48VDC/60A
- Monophase 220V
- Recharge cycle from 0 to 100% (hours)*: 5



ZERO EMISSIONS

STANDARD EQUIPMENT



Construction



Large Events



Aircraft maintenance
Ship repair



Plant Service



Oil & gas



Restoration

ETB18RT

Max. working height	18.16 m
Max. basket height	16.16 m
Max. reach	11.42 m
Max. platform load capacity	250 kg
Max. Occupants	2
Max. gradeability (stowed)	40%
Max. working slope	X-5°/Y-5°
Max. wind speed	12.5 m/s
Turning radius (outside)	4.49 m
Turning radius (inside)	2.92 m
Turret rotation (continuous)	360°
Jib type	Regular
Jib length	1.5 m
Jib movement	-
Jib vertical rotation	132°
Basket width	0.79 m
Basket length	1.83 m
Basket rotation	180°
Total weight	6,830 kg
Travel speed (closed config.)	6.0 km/h
Travel speed (working config.)	1.1 km/h
Tyres	315/55D20
Battery Type	TIANNENG - Lead-acid battery
Powersource	48V/375Ah
Charger	48VDC/60A
Charger type	Monophase 220V
Recharge cycle from 0 to 100% (hours)*	5
Emergency power system	-
Driving motors	34VAC/9kW
Lifting motors	34VAC/13kW
Engine pump	-
Hydraulic tank capacity	145 l
Transmission	Hydrostatic

*Experimental calculation. The count is affected by climate and usage of the machine.

STANDARDS COMPLIANCE: EN 280, ANSI/SAIA A92.20

LOAD CHART

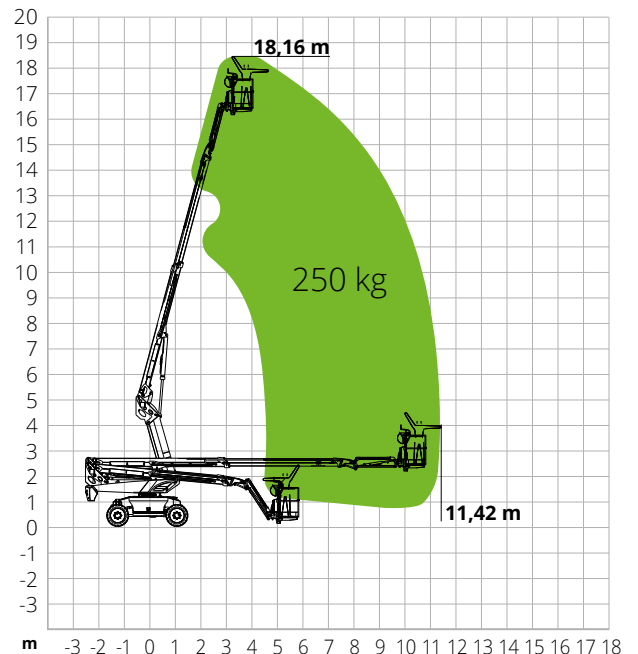

DIMENSIONS

A Platform length	8.40 m
Platform length (transport)	6.48 m
B Platform width	2.33 m
Platform width (transport)	2.33 m
C Platform height	2.49 m
Platform height (transport)	2.60 m
E Wheelbase	2.30 m
Tailswing	1.24 m
D Ground clearance	0.31 m

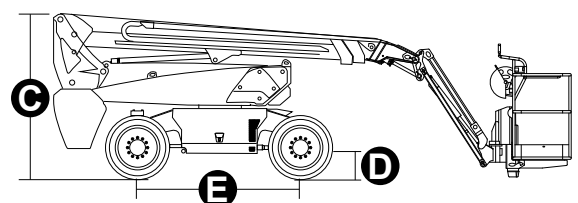
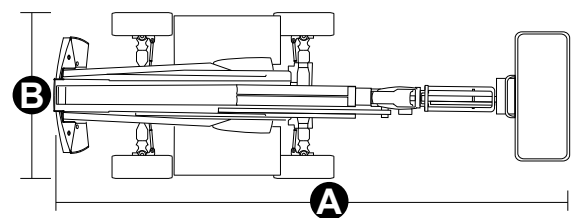

#LIFTDIFFERENT

www.magnith.com



The data in this brochure are provided for the purposes of information and subject to change without notice.