



CONSTRUCTION



LOGISTICS



MINING &
QUARRYING



OIL



TH

7.10 P

TH
7.10 P



CAB

Best-in-class
safety and visibility



PERFORMANCE

Unrivalled lifting
performance



LOAD LIVE DIAGRAM

Two real-time dynamic
load charts

TH

DIMENSIONS (mm)

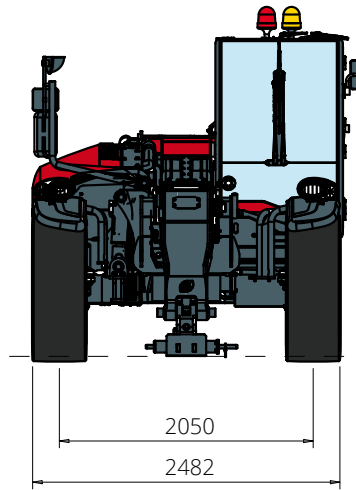

FRONT
view

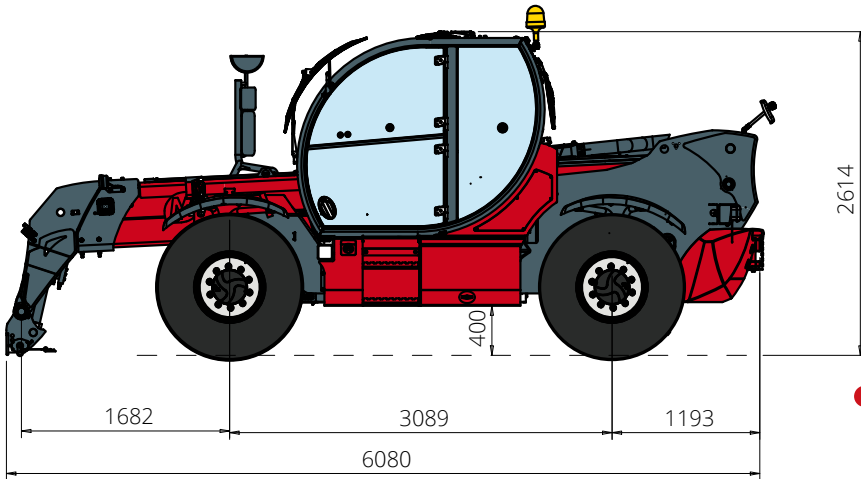

SIDE
view

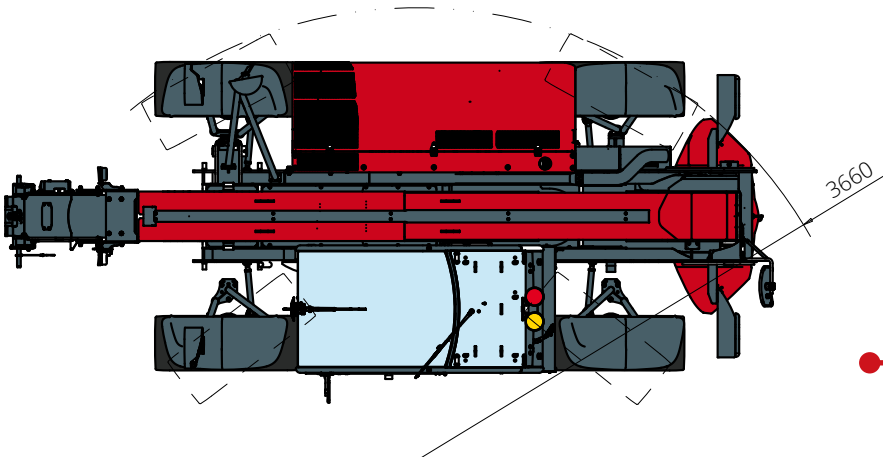

TOP
view

Load chart
FRONT ATTACHMENT ON TYRES

ATT - 03 - 011

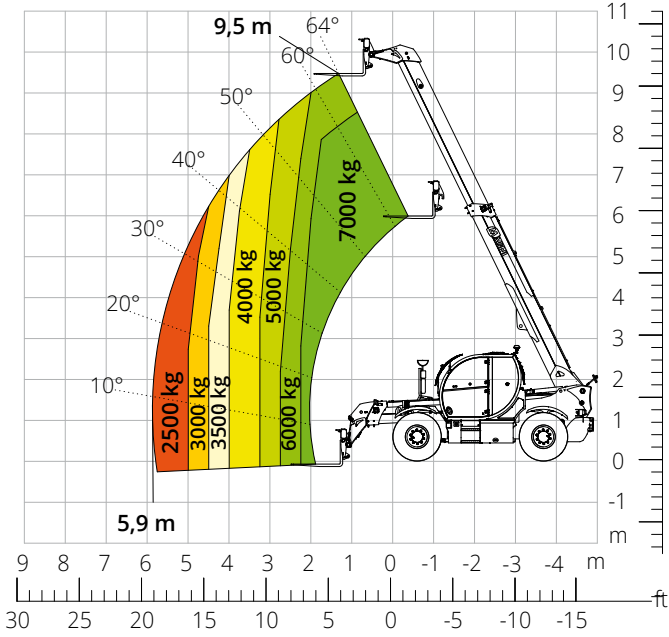

Load chart with
WINCH 3,500 kg

ATT - 02 - 002

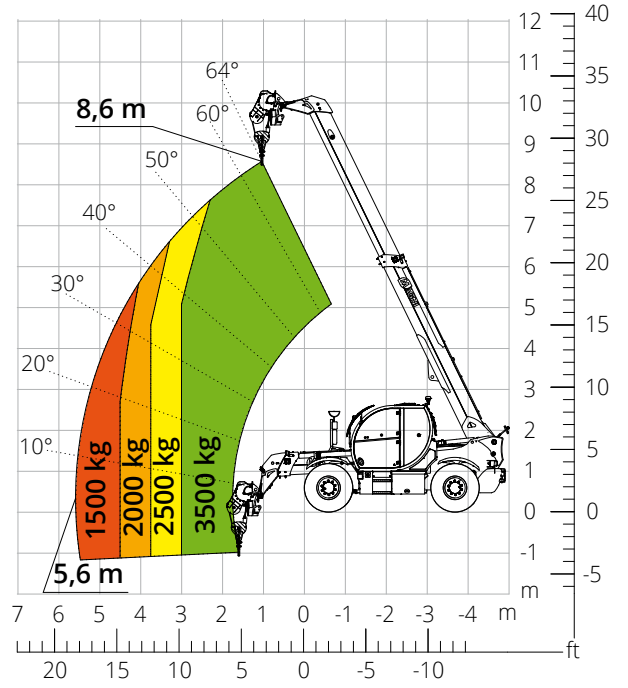

Load chart with
WINCH 6,000 kg

ATT - 02 - 004

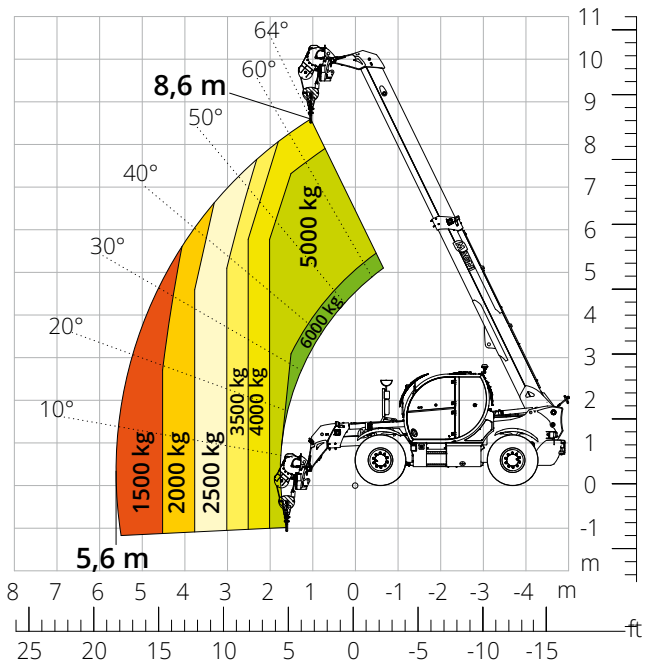

Load chart with
JIB WITH WINCH 1,500 kg

ATT - 04 - 011

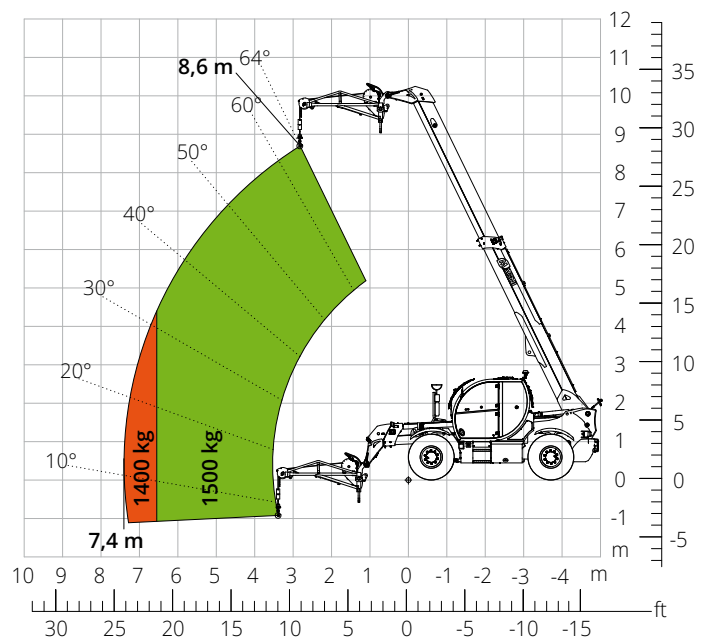

Load chart with
JIB WITH WINCH 2,000 kg
 ATT - 04 - 015

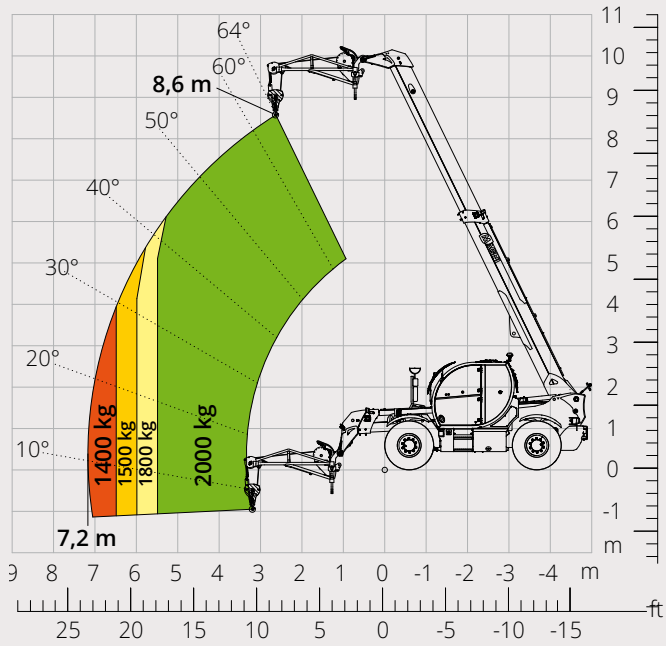

Load chart with
JIB WITH WINCH 3,000 kg
 ATT - 04 - 019

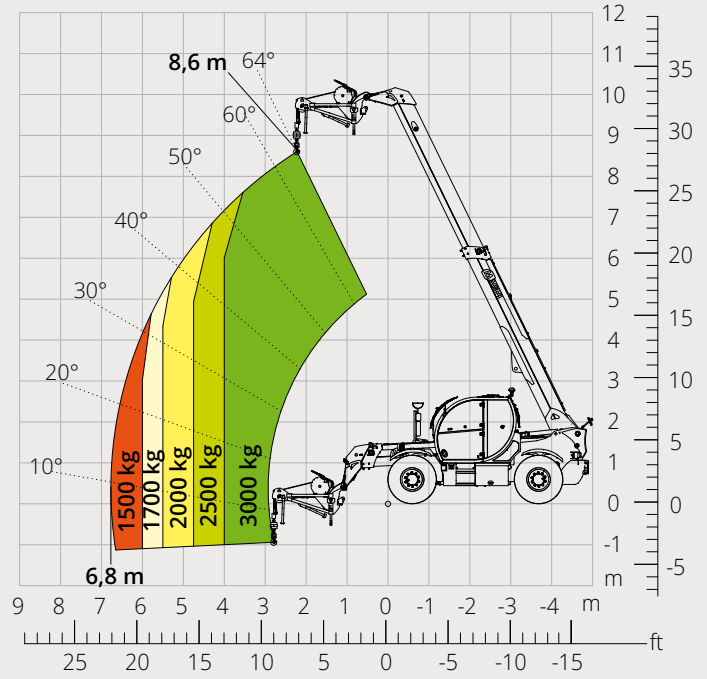

Load chart with
JIB 2,000 kg
 ATT - 04 - 013

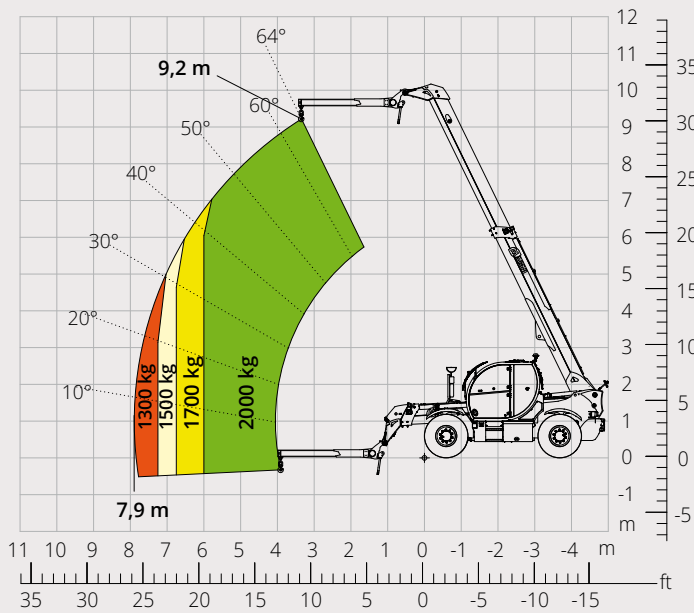

Load chart with
HOOK, 7,000 kg
 ATT - 05 - 002

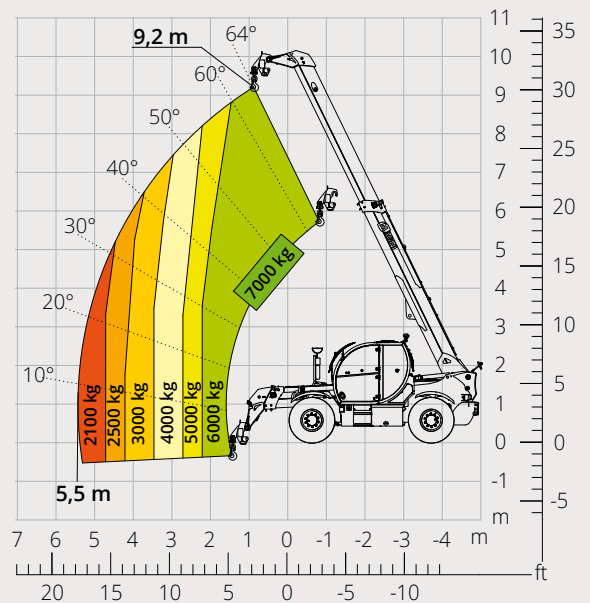

Load chart with
TYRE HANDLER, 2,500 kg

ATT - 06 - 003

Load chart with
ROTATING PLATFORM 250 kg

ATT - 01 - 003

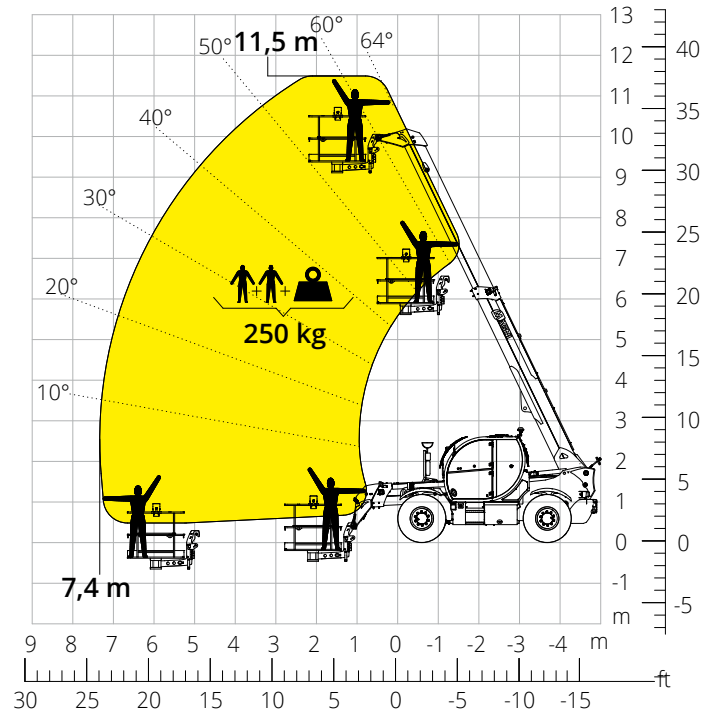
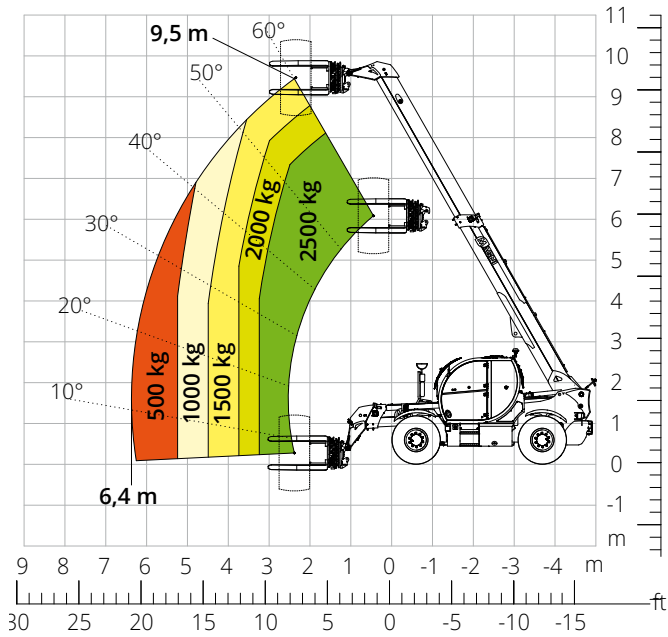

Load chart with
PLATFORM, 450 kg, FOR MINES

ATT - 01 - 027

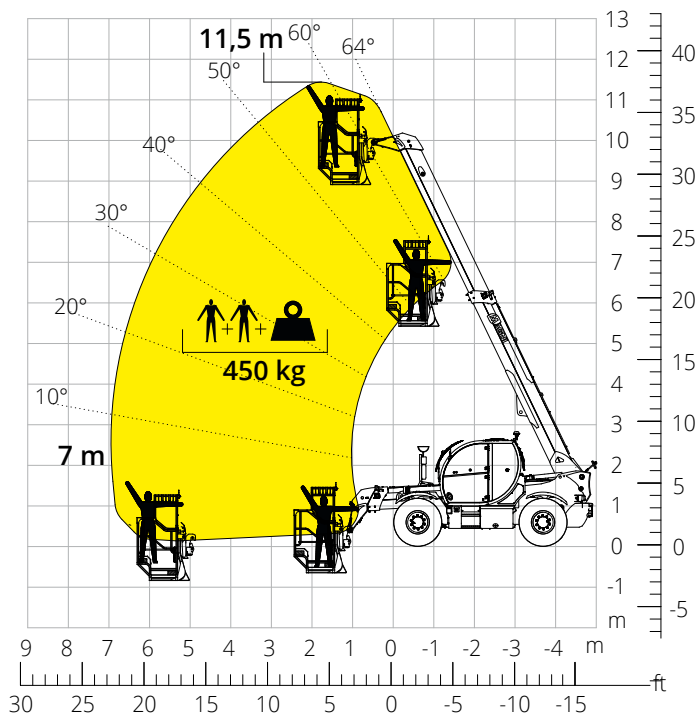

Machine model	Telescopic handler	TH 7.10 P	
	Maximum lifting capacity	7,000 kg	
	Maximum lifting height	9.50 m	
	Maximum reach	5.90 m	
Stabilizer	Type	-	
Engine	Model	Deutz TCD 3,6 L4 EDG Stage IIIA	Deutz TCD 3,6 L4 Stage V
	Rated power	74.4 kW (101.2 hp) at 2,200 rpm	
	Maximum torque	410 Nm at 1,600 rpm	
	Displacement	3,6 l	
	Cylinders	4 in line	
	Engine configuration	Turbocharged direct injection diesel	
	Cooling system	Water – intercooler	
Transmission	Type	Hydrostatic	
	Maximum pressure	500 bar	
	Gear box	Dropbox, 2 speeds forward-reverse	
Axles and brakes	Type	Axles with planetary gearboxes	
	Front axle	Oscillating and steering with levelling, +/-8°	
	Rear axle	Oscillating and steering with hydraulic lock	
	No. of driving/steering wheels	4WD - 4WS	
	Steering mode	Frontal/Concentric/Crab	
	Service brake	Wet multi-disk on front and rear axle	
	Parking brake	Hydraulic with negative action on front axle	
Performance	Tyres dimensions	445/65 R22.5	
	Max. travel speed	35 km/h	
	Maximum mass towable on hook	3,100 kg	
	Gradeability	39%	
Weights	Turning radius (end of forks)	NA	
	Total unladen*	12,000 kg	
	Front axle unladen (boom retracted and lowered)*	3,950 kg	
	Rear axle unladen (boom retracted and lowered)*	8,050 kg	
Tank and system capacities	Fuel tank	145 l	
	AdBlue	10 l	
	Hydraulic oil tank	93 l	
	Engine oil tank	9 l	
Hydraulic circuit for movements	Cooling liquid	20 l	
	Circuit type	Load sensing	
	Service pump	Variable displacement	
	Max. hydraulic flow rate	120 l/min	
	Max. boom head flow rate	75 l/min	
	Max. operating system pressure	350 bar	
	Controls for boom movements	SIL 2 electro-proportional valve	
Movements control	1 joystick with integrated manoeuvre enable		
Standard met	2006/42/EC: EU Machinery Directive		
	2016/1628: EU Regulation on the emissions of stage V engines		
	EN 1459-X: Relating to standards on the safety requirements for variable reach machines		
	EN 280/EN 280-1/EN 280-2: standards relating to mobile elevating work platforms (if available)		
ROPS/level 2 FOPS: relating to the standards for protective structures			

The data given in this brochure are provided for information purposes and are subject to change without prior notice.

All images are purely guideline and might not give an exact representation of the product.

**the stated weight refers to the vehicle unladen with standard equipment and may vary depending on the chosen configuration.*

The standard machine configuration includes:

CAB

- Comfort seat with adjustable headrest
- Adjustable steering column
- Analogue joypad
- Adjustable sunblind
- Heating
- Ambient LED lights
- USB Type-A and Type-C (5 V) inputs

REAL TIME INFORMATION

- Touchscreen, 7"
- MCTS – Magni Combi Touch System on-board software
- Automatic RFID tools recognition system
- LMI – Load Moment Indicator
- LLD – Live Load Diagram
- Onboard and remote integrated diagnostics

TECHNICAL SPECIFICATIONS

- Q-Fit standard
- Advanced three-line CAN BUS system
- Automatic front and rear wheel alignment
- Automatic parking brake
- Mechanical battery cut-off in engine compartment
- Electrical system: 24 V – IP67

SERVICE

- Warranty: 24 months/2,000 hours