



HTH 12.10



MINING &
QUARRYING



HEAVY
LOGISTICS



DEFENCE

Load chart
FRONT ATTACHMENT ON TYRES
 ATT-03-013

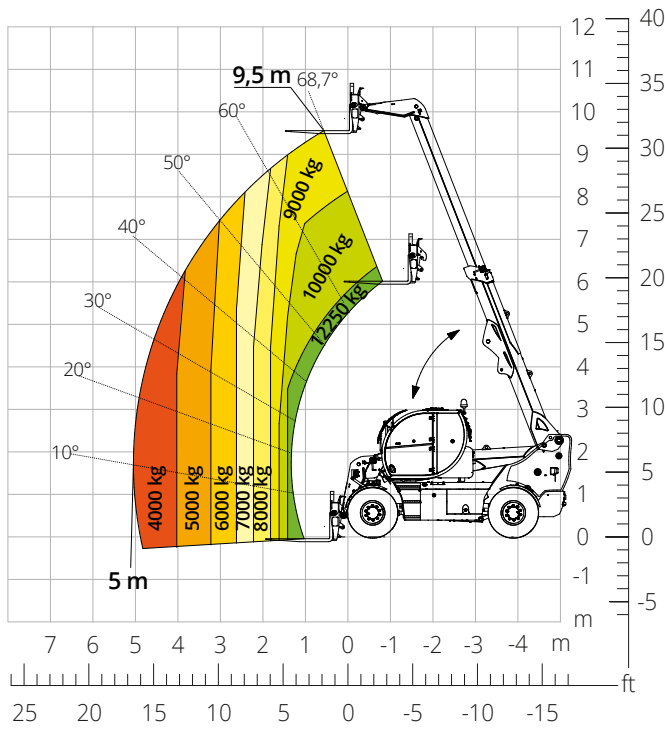

Load chart with
HOOK, 13,000 kg
 ATT-05-013

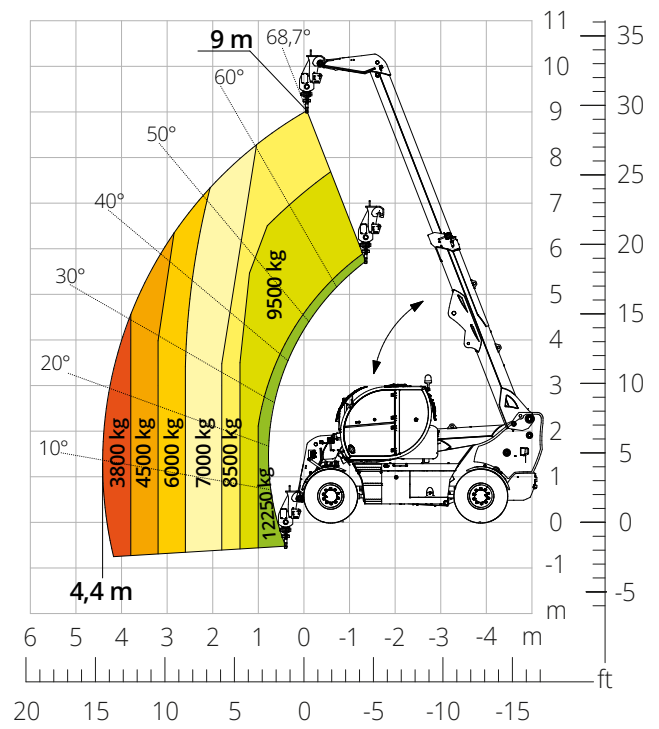

Load chart with
FORKS WITH POSITIONER, 12,000 kg
 ATT-03-050

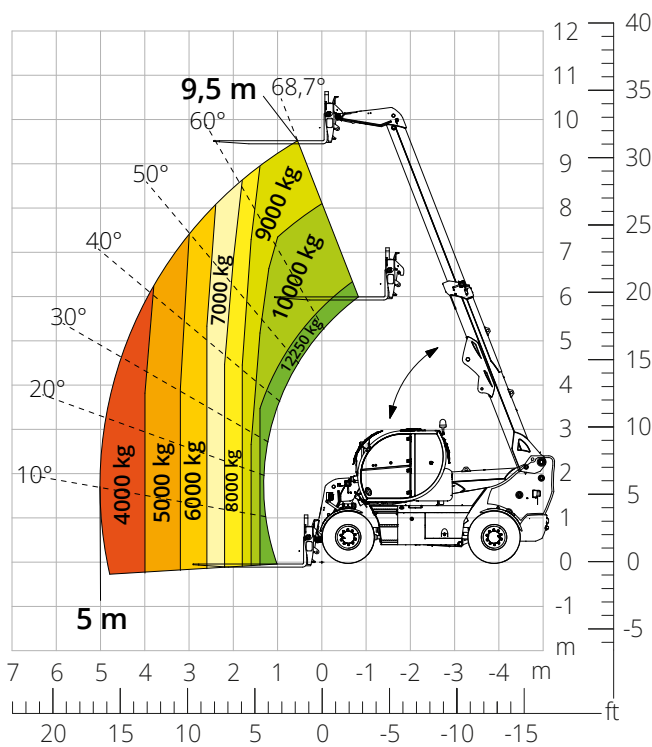

Load chart with
TYRE HANDLER, 3,800 kg
 ATT-06-005

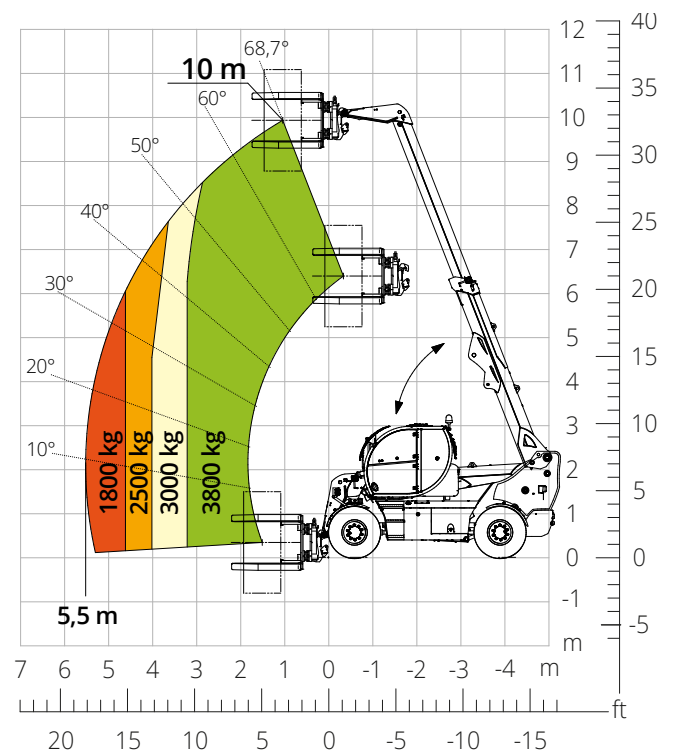

Machine model	Telescopic handler	HTH 12.10	
	Maximum lifting capacity	12,000 kg	
	Maximum lifting height	9.50 m	
	Maximum reach	5.00 m	
Engine	Model	Deutz TCD 3,6 L4-Stage V	Deutz TCD 3,6 L4-Stage IIIA
	Rated power	100 kW (136 hp) at 2,200 rpm	
	Maximum torque	500 Nm at 1,600 rpm	
	Displacement	3,62 l	
	Cylinders	4 in line	
	Engine type	Turbocharged direct injection common rail diesel	
	Cooling system	Water – intercooler	
Transmission	Type	Hydrostatic	
	Maximum pressure	450 bar	
	Gearbox	Dropbox, 2 speeds forward-reverse	
Axles and brakes	Type	Heavy-duty with planetary gearboxes	
	Front axle	Steering and levelling	
	Rear axle	Steering and oscillating	
	No. of driving - steering wheels	4WD - 4WS	
	Steering mode	Frontal/Concentric/Crab	
	Service brake	Servo-assisted pedal, acting on front and rear wheels	
	Parking brake	Hydraulic with negative action on front and rear axles	
	Tyre sizes	18 R22.5	
Performance	Max. travel speed	40 km/h	
	Gradeability (unladen)	63%	
	Turning radius	4,100 mm	
Weights	Total unladen*	15,100 kg	
	Front axle unladen (boom retracted and lowered)*	4,200 kg	
	Rear axle unladen (boom retracted and lowered)*	10,900 kg	
Tank and system capacities	Diesel fuel	195 l	
	AdBlue	10 l	
	Hydraulic fluid	210 l	
	Engine oil	9 l	
	Coolant	25 l	
Hydraulic circuit for movements	Circuit type	Load sensing	
	Service pump	Variable displacement	
	Max. hydraulic flow rate	156 l/min	
	Max. boom head flow rate	75 l/min	
	Max. working pressure	400 bar	
	Distributor for boom movements	Proportional hydraulic distributor	
	Movements control	Multifunction electro-proportional joystick	
Standards met	2006/42/EC: EU Machinery Directive 2016/1628: EU Regulation on the emissions of stage V engines EN 1459-X: Relating to standards on the safety requirements for variable reach machines EN 280/EN 280-1/EN 280-2: standards relating to mobile elevating work platforms (if available) ROPS/level 2 FOPS: relating to the standards for protective structures		

The data given in this brochure are provided for information purposes and are subject to change without prior notice.

All images are purely guideline and might not give an exact representation of the product.

**the stated weight refers to the vehicle unladen with standard equipment and may vary depending on the chosen configuration.*

HTH 12.10

DIMENSIONS (mm)

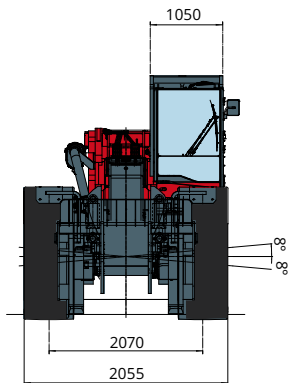

FRONT
view

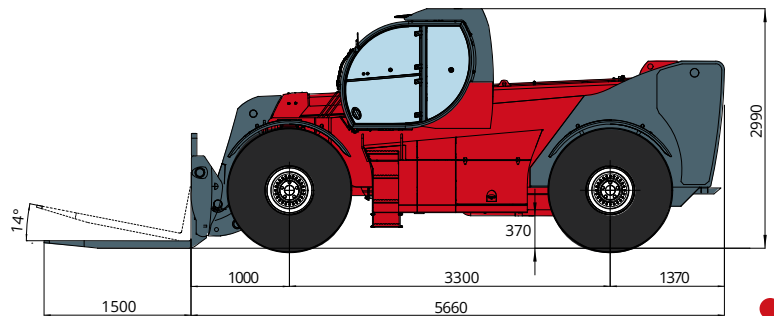

SIDE
view

TOP
view

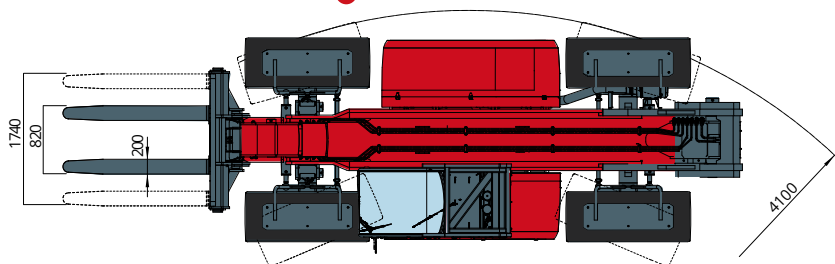

The standard machine configuration includes:

CAB

- Comfort seat
- Adjustable steering column
- Analogue joypad
- Heating
- Air conditioning
- FM/AM radio with USB and Bluetooth connectivity
- USB Type-A (5 V) inputs

REAL TIME INFORMATION

- Touchscreen, 7"
- MCTS – Magni Combi Touch System on-board software
- Automatic RFID tools recognition system
- LMI – Load Moment Indicator
- Onboard and remote integrated diagnostics

TECHNICAL SPECIFICATIONS

- Q-Fit Heavy-Duty
- Two-line CAN BUS system
- Automatic front and rear wheel alignment
- Automatic parking brake
- Mechanical battery cut-off in engine compartment
- Electrical system: 24 V – IP67

SERVICE

- MyMagni by Trackunit connectivity system (2 years)
- Warranty: 24 months/2,000 hours