

**IN**  
**OUT****4WD****2WS**

# ETB18RT

## Telescopic boom lifts



### STANDARD EQUIPMENT

- Oscillating front axle
- Two travel speeds
- Two-wheel steering
- Four-wheel drive
- 360° rotation (continuous)
- Special construction equipment-grade integral driveshaft
- Proportional controls
- Thumb rocker steering
- Flashing light
- Non-marking tyres
- Horn
- Hour counter
- Harsh environment kits
- 12V DC Auxiliary power

### BATTERY

- TIANNENG - Lead-acid battery
- Battery capacity: 48 V/375 Ah
- Charger: 48V DC/60 A
- Single-phase 220 V
- Recharge time, 0 - 100% (hours)\* 5

### BASKET

- Self-levelling
- Rotation +/-90°
- Schuko power socket 16A/250 V

### SAFETY

- Drive enable system
- Platform load moment indicator
- On-board diagnostics system
- Emergency lowering system
- Tilt indicator with alarm
- Crushing protection

**CONSTRUCTION****LOGISTICS**

## LOAD CHART

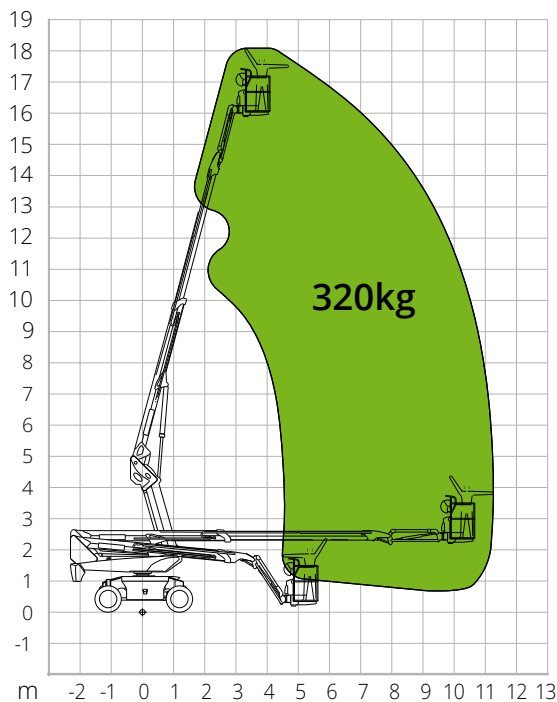

## DIMENSIONS

Platform length (transport)	6.48 m
Platform width (transport)	2.44 m
Platform width (axle expanded)	-
Platform width (axle retracted)	-
Platform height (transport)	2.68 m
Wheelbase	<b>B</b> 2.40 m
Wheelbase (axle extended)	-
Wheelbase (axle retracted)	-
Tailswing	1.18 m
Ground clearance	<b>A</b> 0.31 m

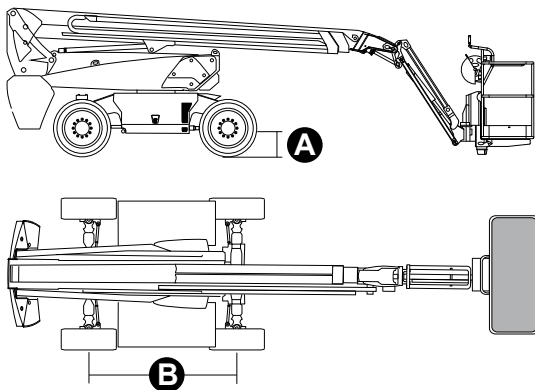

**STANDARDS COMPLIANCE:** EN 280-1, ANSI/SAIA A92.20

The data given in this brochure are provided for information purposes and are subject to change without prior notice. All images are purely guideline and might not give an exact representation of the product.

## ETB18RT

### Technical data

Max. working height	18.26 m
Max. basket height	16.26 m
Max. reach	11.32 m
Turning radius (outside)	4.73 m
Turning radius (inside)	3 m
Basket width	0.79 m
Basket length	1.83 m
Basket rotation	180°
Jib type	Standard
Jib length	1.5 m
Jib Vertical Rotation	132°
Jib travel angle	-
Auxiliary power	12V DC

### Performance

Platform max. load capacity	320 kg
Max. occupants	2
Max. gradeability (stowed)	40%
Max. working slope	X-5°/Y-5°
Max. wind speed	12.5 m/s
Travel speed (closed config.)	6.0 km/h
Travel speed (working config.)	1.1 km/h
Turret rotation (continuous)	360°

### Engine

Travel power	34 AC/9 kW
Drive pump	-
Hydraulic tank capacity	145 l
Transmission	Hydrostatic

### Specific characteristics

Tyres	315/55D20
Battery type	TIANNENG - Lead-acid battery
Battery capacity	48V/375Ah
Charger	48VDC/60A
Charger type	Single-phase 220 V
Recharge time, 0 - 100% (hours)*	5
Lifting motors	34VAC/13kW
<b>Total weight</b>	<b>7,750 kg</b>

\*Nominal. The actual value depends on weather and usage factors