



# ETB41RT

## Telescopic boom lifts

### STANDARD EQUIPMENT

- Two travel speeds
- Four-wheel steering
- Four-wheel drive
- Patented extending chassis
- On-site axle extension
- 360° rotation (continuous)
- Turret locking system
- Ultra-rigid boom
- Special construction equipment-grade integral driveshaft
- Hydraulic oil radiator
- Proportional controls
- Flashing light
- Non-marking tyres
- Horn
- Hour counter
- Casing opens for easier servicing
- Negative pressure brake with sensor
- Real-time on-board system
- Platform rotation angle monitoring sensor
- Chain malfunction monitoring
- Working condition monitoring
- Rexroth hydrostatic drive system
- Harsh environment kits
- 12V DC Auxiliary power

### BATTERY

- Lithium battery - Maintenance-free
- Battery capacity: 358.4 V/200 Ah
- Charger: 48V DC/60 A
- Three-phase 380 V
- Recharge time, 0 - 100% (hours)\* 12

### BASKET

- Self-levelling
- Rotation +/-90°
- Schuko power socket 16A/250 V

### SAFETY

- Drive enable system
- Platform load moment indicator
- On-board diagnostics system
- Tilt indicator with alarm
- Basket bottom protection sensor
- Lowering and travel alarms
- Crushing protection
- Cat.3 Safety Architecture - ISO 13849-1



CONSTRUCTION



LOGISTICS

## LOAD CHART

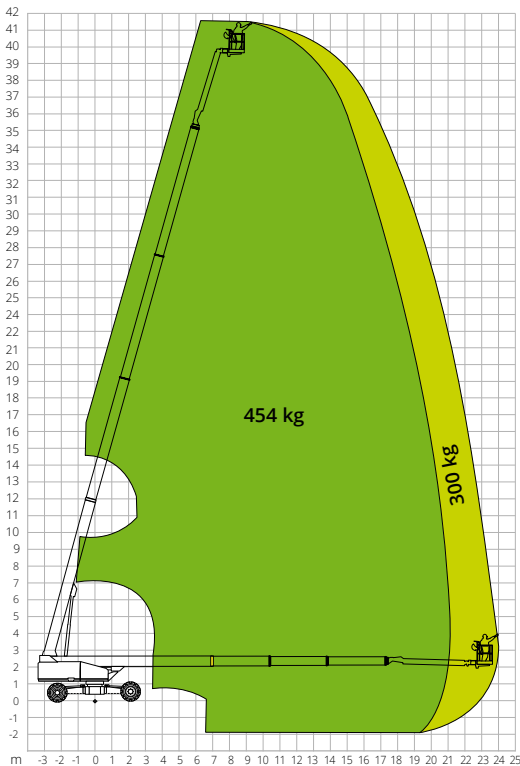

## DIMENSIONS

Platform length (transport)	11.17 m
Platform width (transport)	2.44 m
Platform width (axle expanded)	4.17 m
Platform width (axle retracted)	<b>A</b> 2.44 m
Platform height (transport)	2.83 m
Wheelbase	-
Wheelbase (axle extended)	4.07 m
Wheelbase (axle retracted)	<b>B</b> 4.27 m
Tailswing	1.39 m
Ground clearance	0.40 m

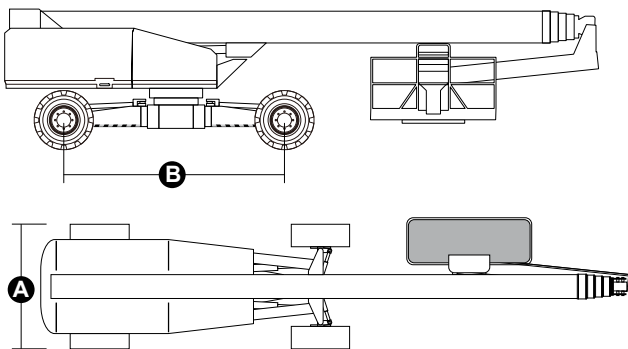

### STANDARDS COMPLIANCE: EN 280-1, ANSI/SAIA A92.20

The data given in this brochure are provided for information purposes and are subject to change without prior notice. All images are purely guideline and might not give an exact representation of the product.

## ETB41RT

### Technical data

Max. working height	36.23 m
Max. basket height	34.23 m
Max. reach	23.60 m
Turning radius (outside)	5.41 m
Turning radius (inside)	2.99 m
Basket width	0.91 m
Basket length	2.44 m
Basket rotation	180°
Jib type	Standard
Jib length	4.20 m
Jib Vertical Rotation	230°
Jib travel angle	75°
Auxiliary power	12V DC

### Performance

Platform max. load capacity	300/454 kg
Max. occupants	3
Max. gradeability (stowed)	30%
Max. working slope	5°
Max. wind speed	12.5 m/s
Travel speed (closed config.)	6.0 km/h
Travel speed (working config.)	1.1 km/h
Turret rotation (continuous)	360°

### Engine

Travel power	-
Drive pump	-
Hydraulic tank capacity	230 l
Transmission	Hydrostatic

### Specific characteristics

Tyres	445/50-D710
Battery type	Lithium battery - Maintenance-free
Battery capacity	200Ah/358.4V
Charger	358.4V/32A
Charger type	Three-phase 380 V
Recharge time, 0 - 100% (hours)*	12
Lifting motors	-

**Total weight** 21,060 kg

\*Nominal. The actual value depends on weather and usage factors