

**IN**
OUT**4WD****2WS**

HTB16RT

Telescopic boom lifts



STANDARD EQUIPMENT

- Oscillating front axle
- Two travel speeds
- Two-wheel steering
- Four-wheel drive
- 360° rotation (continuous)
- Special construction equipment-grade integral driveshaft
- Proportional controls
- Thumb rocker steering
- Flashing light
- Non-marking tyres
- Horn
- Hour counter
- Harsh environment kits
- 12 V DC Auxiliary power

BATTERY

- TIANNENG - Lead-acid battery
- Battery capacity: 48 V/300 Ah
- Charger: 48V DC/60 A
- Single-phase 220 V
- Range Extender engine: Kubota Z482/9.8 kW
- Recharge time, 0 - 100% (hours)* 5

BASKET

- Self-levelling
- Rotation +/-90°
- Schuko power socket 16A/250 V

SAFETY

- Drive enable system
- Platform load moment indicator
- On-board diagnostics system
- Emergency lowering system
- Tilt indicator with alarm
- Crushing protection

**CONSTRUCTION****LOGISTICS**

LOAD CHART

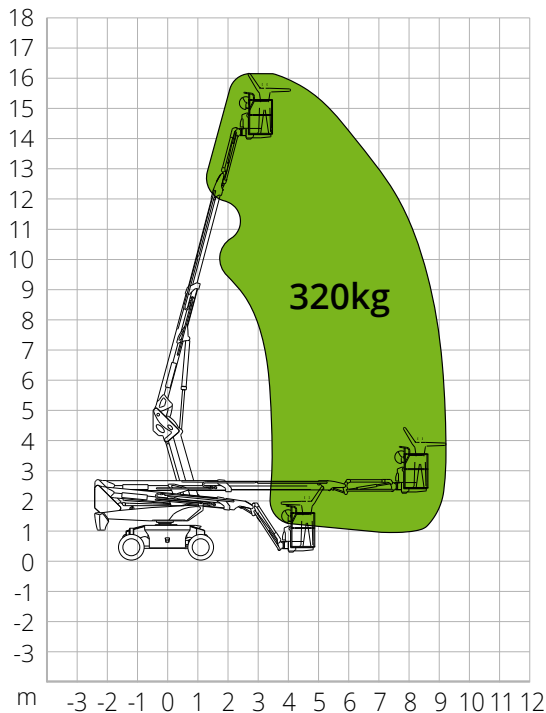

DIMENSIONS

Platform length (transport)	5.48 m
Platform width (transport)	2.44 m
Platform width (axle expanded)	-
Platform width (axle retracted)	-
Platform height (transport)	2.68 m
Wheelbase	B 2.40 m
Wheelbase (axle extended)	-
Wheelbase (axle retracted)	-
Tailswing	1.18 m
Ground clearance	A 0.31 m

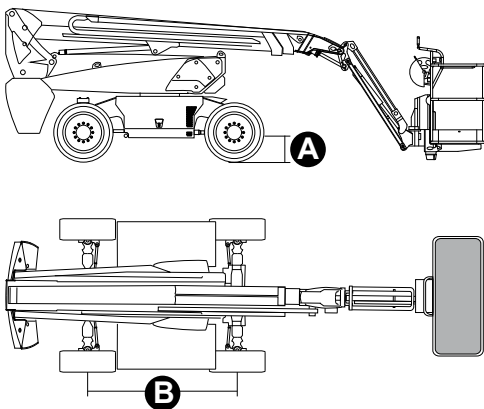

STANDARDS COMPLIANCE: EN 280-1, ANSI/SAIA A92.20

The data given in this brochure are provided for information purposes and are subject to change without prior notice. All images are purely guideline and might not give an exact representation of the product.

HTB16RT

Technical data

Max. working height	16.33 m
Max. basket height	14.33 m
Max. reach	9.32 m
Turning radius (outside)	4.73 m
Turning radius (inside)	3 m
Basket width	0.79 m
Basket length	1.83 m
Basket rotation	180°
Jib type	Standard
Jib length	1.5 m
Jib Vertical Rotation	132°
Jib travel angle	-
Auxiliary power	12 V DC

Performance

Platform max. load capacity	320 kg
Max. occupants	2
Max. gradeability (stowed)	40%
Max. working slope	X-5°/Y-5°
Max. wind speed	12.5 m/s
Travel speed (closed config.)	6.0 km/h
Travel speed (working config.)	1.1 km/h
Turret rotation (continuous)	360°

Engine

Travel power	34 AC/9 kW
Drive pump	-
Range Extender engine	Kubota Z482/9.8 kW
Diesel tank capacity	90 l
Hydraulic tank capacity	145 l
Transmission	Hydrostatic

Specific characteristics

Tyres	315/55D20
Battery type	TIANNENG - Lead-acid battery
Battery capacity	48V/300Ah
Charger	48VDC/60A
Charger type	Single-phase 220 V
Recharge time, 0 - 100% (hours)*	5
Lifting motors	34VAC/13kW
Total weight	7,150 kg

*Nominal. The actual value depends on weather and usage factors